



ACRYLIC SHEET

Forming Manual

TABLE OF CONTENTS

3 Introduction

4 Methods of Heating

- 4 Air Oven Heating
- 6 Air-Operated Release for Oven Clamps and Clamping Station
- 6 Infrared Radiant Heating
- 8 Strip Heating
- 9 Other Methods of Heating
- 9 Special Considerations for Forming Plexiglas® MC acrylic sheet

11 Forming Temperatures and Cycles

- 12 Time Available for Forming
- 12 Slow Cooling
- 12 Reforming

13 Forming Equipment

- 13 Presses
- 13 Clamp Rings and Clamps
- 17 Vacuum Forming Equipment

19 Forms for Plexiglas® Acrylic Sheet

- 19 Contour Tolerances and Effects of Forming
- 19 Shrinkage Allowances
- 19 Materials for Forms
- 19 Wood Forms
- 19 Resin Impregnate Forms
- 20 Metal Forms
- 20 Cast Forms
- 20 Gypsum Forms
- 21 Resin Forms
- 21 Surfaces of Forms
- 21 Grease-Covered Forms

22 Forming Methods

- 22 Preparation of Sheets for Forming
- 22 Two-Dimensional Forming
- 22 Cold Forming
- 22 Strip Heat Bending
- 23 Drape Forming
- 23 Three-Dimensional Forming
- 24 Free Forming
- 26 Estimating Pressure Required for Free Blowing or Vacuum Forming
- 26 Vacuum Snapback Forming
- 26 Vacuum Drawing or Blowing into a Form
- 28 Manual Stretch Forming
- 29 Slip Forming
- 29 Plug and Ring Forming
- 29 Vacuum Assist Plug and Ring Forming
- 30 Blowback Forming
- 31 Billow Forming
- 32 Ridge Forming
- 33 Male and Female Forming
- 33 Surface Embossing

34 General Health and Safety Precautions

INTRODUCTION

One of the most useful properties of Plexiglas® acrylic sheet is its thermoformability. Being thermoplastic, it becomes soft and pliable when heated and can then be formed to almost any desired shape. As the material cools, it stiffens and retains the shape to which it has been formed.

The size, shape and optical requirements of the formed part generally govern the choice of forming method to be used. Regardless of the method used, the following principles must be observed for best results.

1. The whole sheet should be heated uniformly to the proper forming temperature (Exception: see Strip Heating, page 8).
2. The sheet should be completely formed before it cools below the minimum forming temperature.
3. The part should be cooled slowly and uniformly while being held in its formed shape and removed from the mold while still warm.

Most of the information in this Manual is applicable for all grades of Plexiglas® acrylic sheet, except for some applications related to Plexiglas® MC acrylic sheet. Any exceptions are noted in the appropriate sections.

METHODS OF HEATING

Forced-circulation air oven heating provides the best protection against overheating the sheet, develops the least amount of temperature gradient throughout the thickness of the sheet, results in longer heating cycles, and is highly recommended when heating sheet 0.354 inches and thicker. Infrared heating, which is generally associated with automatic or semi-automatic operations, results in shorter heating cycles, and should be used with sheet thicknesses of less than 0.354 inches. Infrared heating can result in uneven heating, if the heating elements begin to lose their heating ability over time. Infrared heating can degrade the sheet if the heating cycle is exceeded. Strip-heat bending utilizes infrared elements and may degrade the sheet if heating cycles are exceeded. It is limited to two-dimensional forming but is viable for bending sheet thicknesses of up to about two inches. A typical forced-circulation air oven is shown in Figure 1. For heating equipment suppliers and sources of other accessories, call the Altuglas International Polymer Technology Center at 800-217-3258.

Air Oven Heating

Generally, the whole piece of Plexiglas® acrylic sheet is heated before forming in a hot air oven with forced circulation (Figure 1). The basic elements of such an oven are an insulated chamber of sufficient size, which is provided with a means to force-circulate the air, and a means of heating, which may be either gas or electricity.

Gas ovens should be designed with heat exchangers so that the flue gases are not used as the actual heating medium. Baffles should be used to direct the heated air from the heating elements to the Plexiglas® acrylic sheet. The sheet should be protected from radiation to eliminate hot spots.

When an electric oven is to be used, the heating elements should be designed to be easily removed, so that they can be serviced and replaced with ease. It is also desirable to use a switch capable of converting the wiring from series to parallel rather than a simple on-off switch. A series/parallel switch reduces power to the elements when actuated by the thermoregulator but does not switch the power off. This mode of operation provides a more uniform oven temperature.

To prevent thermal damage to the sheet, maximum oven air temperatures should be carefully controlled. Automatic temperature regulators must be provided. Temperature recording devices are desirable, although not absolutely essential. The accuracy of temperature controls should be checked occasionally by means of a maximum reading thermometer hung in the oven near the sheets.

It is extremely important to wire the heater elements and air circulating blowers into the same circuit. If these units are on separate circuits a potential fire hazard exists. In such a case, it would be possible for the heater to be operating when the blowers were not. Without air circulating, the elements could overheat and cause a fire.

Forced circulation of air and suitable baffles are necessary to distribute the heat evenly throughout the oven so that each sheet will be heated uniformly over its entire surface and so that all sheets will be heated to the same temperature. It is very important that air be circulated across the surface of the sheet at a velocity from 150 to 250 cubic feet per minute. For efficient heating, ovens should have two narrow doors to prevent excessive heat loss while loading and unloading the sheets. This will allow for the introduction of large formed parts for reheating and flattening if reforming is necessary.

Small sheets may be supported in trays lined with soft cloth or woven fiberglass cloth or fiberglass coated with sintered Teflon® to protect the surface of the plastic from scratching. Large Plexiglas® acrylic sheets should be hung vertically from racks. Overhead racks for hanging sheets may be equipped with tracks and trolleys leading to forming equipment to facilitate handling of the sheet. Note the Special Considerations section for Plexiglas® MC acrylic sheet on page 9.

FIGURE 1

Typical Forced-Circulation Air Oven

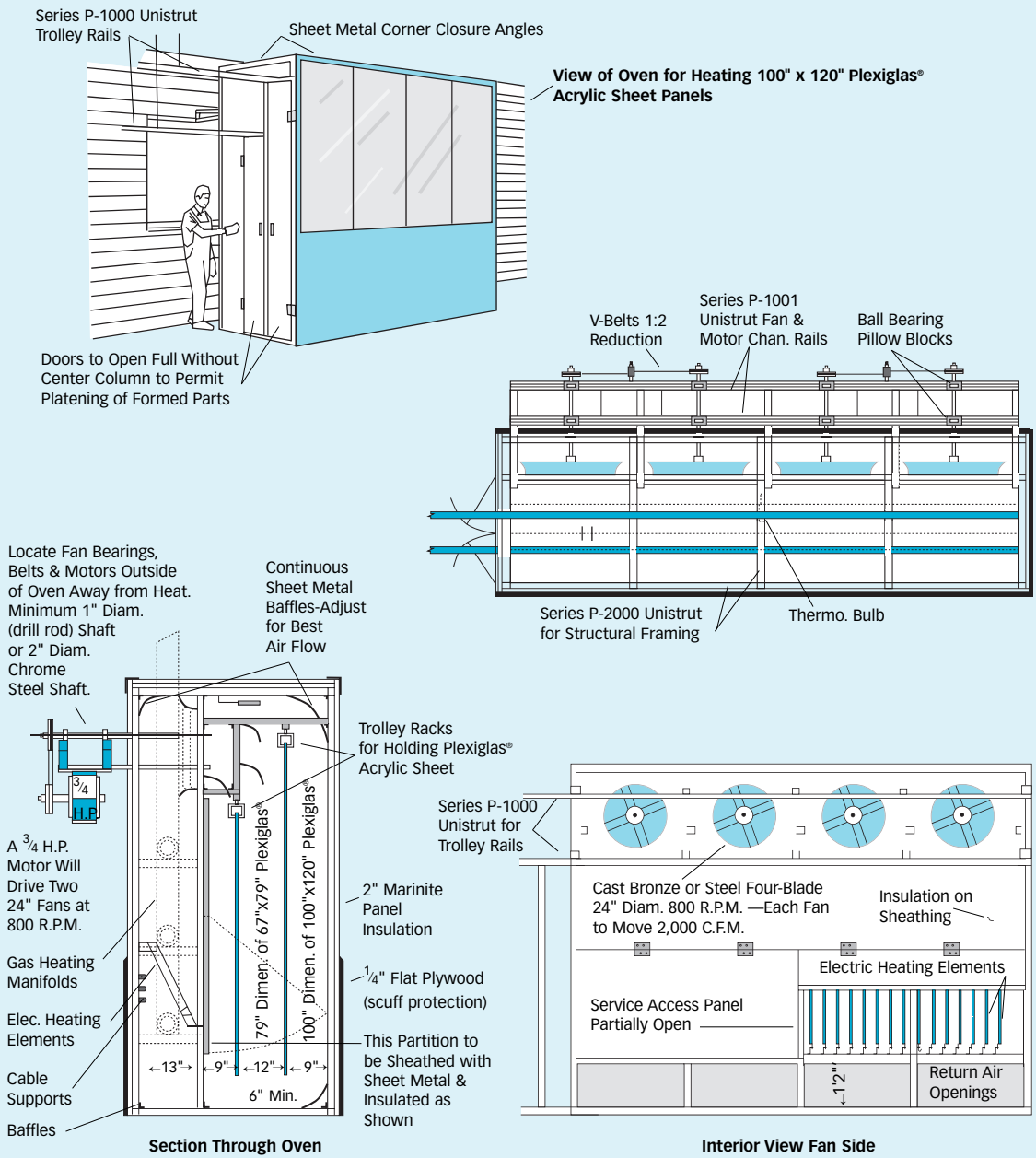

Air-Operated Release for Oven Clamps and Clamping Station

Figure 3 depicts a clamping station with an air-operated release mechanism for hanging Plexiglas® acrylic sheets in heating ovens. This device can reduce appreciably the labor required for clamping and unclamping sheets preparatory to forming. It can also shorten the time required to transport the heated sheet from the oven to the forming equipment, thus minimizing the possibility of cold forming.

The design of the unit permits the operator to open all the clamps at once by simply opening a valve on the air line. After the sheet has been placed in the clamps, they are closed by shutting the air valve and venting the air pressure in the cylinders. The air pressure and vent line can be operated by a foot control so that the fabricator's hands are free to grip the sheet.

In a permanent installation, the clamping station can be welded to the trolley rail. In temporary operations, the station can be moved to various locations and bolted to any section of trolley rail in the shop.

An automatic clamping unit of the type mentioned above is essential for high-volume forming, however, smaller operations can function successfully with less elaborate systems constructed from standard spring paper clips as shown in Figure 2. Spring paper clips, such as Hunt No. 4 or equivalent, are suitable. Naturally, this simpler system involves manually clamping and unclamping the sheet.

FIGURE 2

Sheet-Hanging Device (Air-Operated Release)

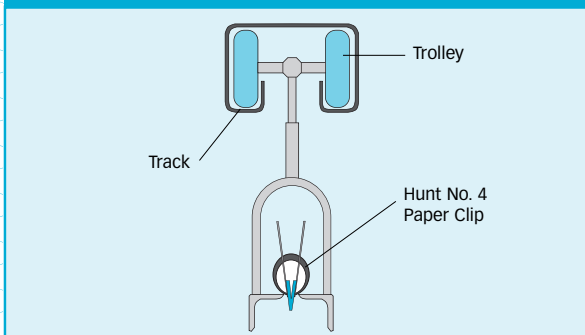

Infrared Radiant Heating

The principal advantage of radiant heating over convection oven heating is speed. Radiant heating time cycles for 0.118-inch thick Plexiglas® acrylic sheet heated from one side may vary from one to three minutes, depending on the type of heater and the distance from the heating surface to the Plexiglas® acrylic sheet compared with about 10 to 12 minutes for air-oven heating. Ambient oven temperature also affects the heating cycle.

Temperature uniformity varies with heater model. Heaters that produce uniform surface temperatures can be located closer to the Plexiglas® acrylic sheet for better energy efficiency.

Since Plexiglas® acrylic sheet is opaque to most wavelengths in the infrared spectrum, the surface exposed to the heater absorbs almost all the energy. The rest of the sheet is heated largely by conduction.

Since Plexiglas® acrylic sheet is an excellent insulator, the surface exposed to the heater may overheat before the rest of the sheet is hot enough for forming. This phenomenon is relatively common in thicker sheet. The rate of radiant heat input can be decreased but that would result in a longer heating cycle. Consequently, for optimum production efficiency, double-sided infrared heaters should be used for sheet 0.118 inches or greater in thickness. Single-sided infrared heaters are not recommended for sheet thicker than 0.177 inches.

Infrared heating time is critical and must be closely controlled because of the high surface temperatures (usually 600°F to 1500°F) of the heaters and the large amount of energy they emit. Infrared heaters are usually controlled by a timing switch on a relay circuit, varying the on-off cycle to meet the requirements of particular forming operations. Fifteen-second cycle timers are recommended; a thermocouple and a controller may be used as well. Varying the distance between the heaters and the sheet regulates the rate of heat input effectively. This distance should be a minimum of two to three times the element spacing to eliminate hot spots.

Infrared radiant heating is not recommended for heating large areas where the most uniform heating is necessary in order to obtain excellent optical properties in the formed part. With infrared heaters, power required is approximately 10 watts per square inch of sheet area.

FIGURE 3

Sheet Hanging Device (Air-Operated Release)

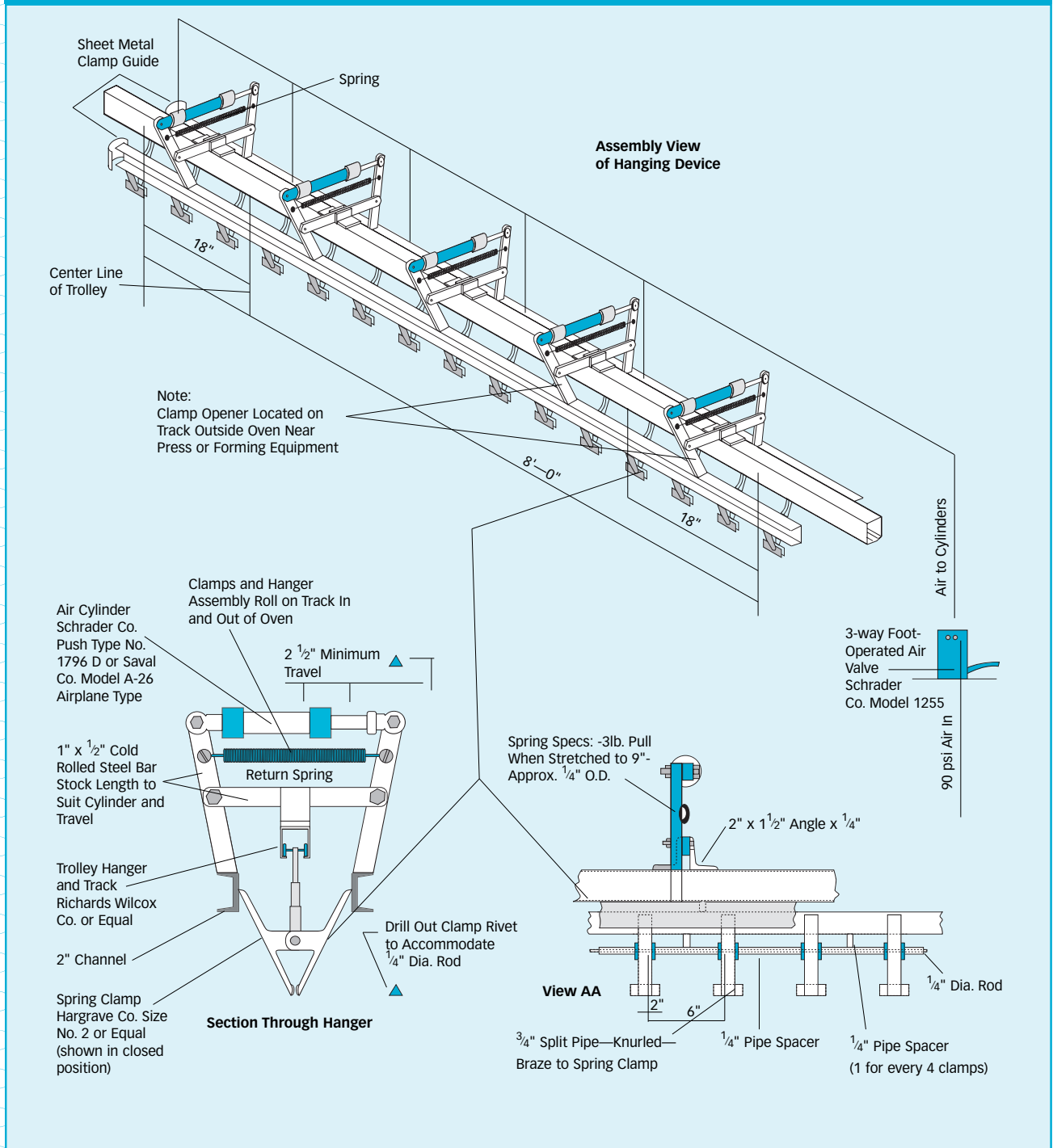
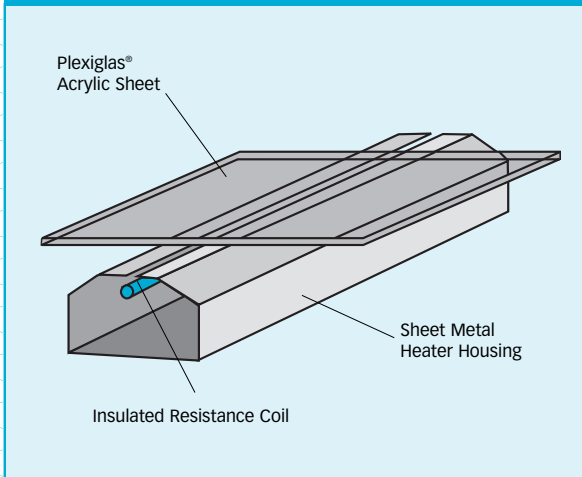

FIGURE 4
Typical Strip Heater



The strip heater should have supports on both sides to hold the Plexiglas® acrylic sheet. See Figure 4. The supports should be parallel to and above the heater so the heater does not touch the surface of the sheet. The supports should be shielded from direct radiation to minimize the temperature. This is especially true for Plexiglas® MC acrylic sheet, which could develop mark-off if too hot. Direct contact with the hot element will destroy or severely distort the surface of Plexiglas® acrylic sheet. Therefore, the material should be kept at least 1/8 inch from the tube. To form a bend with a large arc, a wider band of Plexiglas® acrylic sheet is heated by holding the sheet at a greater distance from the heater or by using a wide strip heater.

To form material more than 0.236 inches thick and for fast production, two heaters should be arranged to heat both surfaces simultaneously.

Plexiglas® MC acrylic sheet can be readily strip heated and bent. Heating cycles will be slightly shorter than those used with Plexiglas® G cell cast acrylic sheet and the material must be closely monitored to prevent overheating (greater than 410°F surface temperature), which can result in surface bubbles. Adhering to the following guidelines will help to ensure satisfactory bends with no bubbling:

- Use a heater that develops an element surface temperature of approximately 800°F (not glowing red), and a sheet support surface temperature of less than 225°F (water cooled if necessary). Maintain a uniform sheet to element spacing of 1/4 inch.
- Heat 3mm (0.118 inches) material from one side for approximately two and a half minutes.
- Preferably, heat 4.5mm (0.177 inches) material from both sides simultaneously. When using a single element heater, flip the sheet every minute for about three minutes.
- Material that is 6mm (0.236 inches) thick should be heated from both sides simultaneously or flipped every minute for about four minutes.

While strip heaters employing hotter elements than 800°F can be used for bending Plexiglas® MC acrylic sheet, the risk of bubbling increases as the element temperature increases. For example, if the sheet is heated 15 seconds too long with a glowing red element (about 1500°F), bubbling is very likely.

Strip Heating

Strip heaters are used to heat Plexiglas® acrylic sheet to forming temperature along a straight line so it can be bent along that line. A strip heater is usually electric with the element made from a nichrome wire resistance coil. The wire should be insulated with china clay tubing or porcelain beads and can also be encased in a copper, Monel®, or Pyrex® tube. Flexible fiberglass-nichrome wire tape strip heaters are available for heating both curved surfaces and flat surfaces.

Selectively heating a narrow area of plastic to forming temperature without heating the adjacent material induces a considerable amount of stress into the bend area upon cooling. This could lead to premature failure by cracking or crazing. Avoid exposing the bend area to materials such as cleaners, solvents, polishes or waxes; although normally safe, these products could craze the surface of the sheet. Warpage can occur in the sheet in very long bends with short legs because of stress relaxation. The only way to ensure against either of these conditions is to heat the entire sheet and cool the bent formed part evenly.

The heater should be equipped with a thermoregulator to prevent overheating the Plexiglas® acrylic sheet.

GRAPH 1

30-Second Modulus Curves

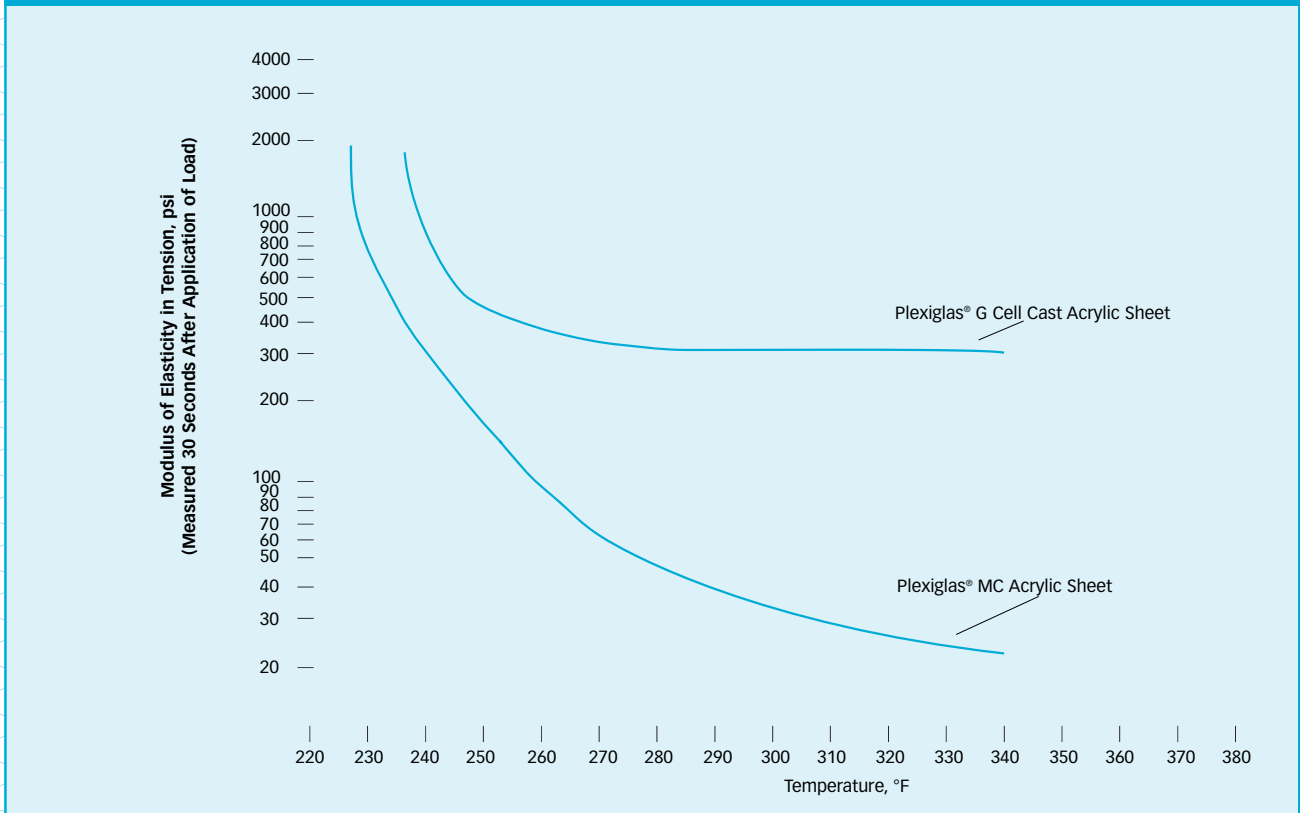

Other Methods of Heating

Hot water or atmospheric pressure steam will not heat acrylic sheet to high enough temperatures for forming.

Hot oil can be used, but it makes the sheet difficult to handle and necessitates subsequent cleaning. A light mineral oil such as transformer oil is preferred. The oil must be kept clean and must be washed off after forming.

Microwave sources do not heat Plexiglas® acrylic sheet efficiently.

Special Considerations for Forming Plexiglas MC Sheet

As the 30-second modulus curves in Graph 1 show, the forming characteristics of Plexiglas® MC acrylic sheet and Plexiglas® G cell cast acrylic sheet differ in certain respects when heated to the same given forming temperature.

Plexiglas® MC acrylic sheet, when heated to a given forming temperature, is somewhat softer than similarly heated cell cast acrylic sheet. Therefore, more clamps should be used with Plexiglas® MC acrylic sheet, and large sheets should be hung in the oven from the long edge to provide maximum support. If heated at too high a temperature or allowed to remain in the oven longer than necessary, the Plexiglas® MC acrylic sheet will tend to “flow,” becoming elongated and narrow, and may

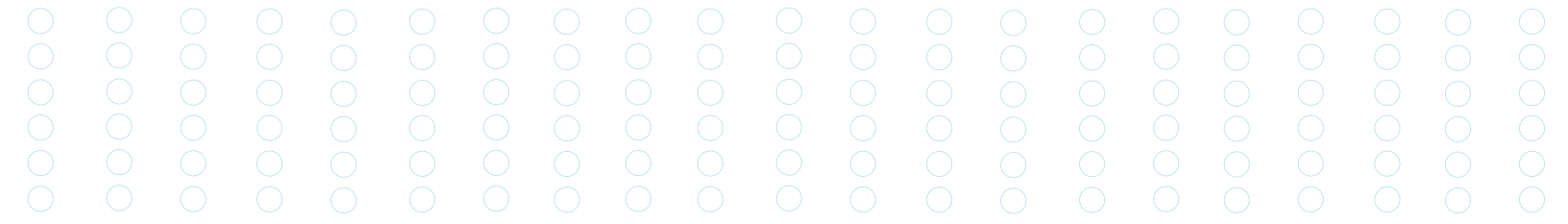

pull out or tear from the supporting clamps. Plexiglas® MC acrylic sheet will also tend to adhere to hot metal clamps. To help prevent problems, preclamp the sheet in a tenter frame before heating.

Heated Plexiglas® MC acrylic sheets will tend to stick together more readily than cast sheets that touch one another in the oven or that are accidentally folded during forming.

Fabricators can avoid thermal damage to Plexiglas® MC acrylic sheet by controlling temperature and heating time cycles to avoid bubbling.

Plexiglas® MC acrylic sheet may require pre-drying overnight at 180°F, if it has been exposed to conditions of high relative humidity for extended periods of time. This situation usually applies only to sheet that will be formed at the upper end of the forming temperature range (greater than 325°F) when extremely sharp detail is desired.

When Plexiglas® MC acrylic sheet is heated without a tenter frame, it will shrink approximately 2 percent in the direction of manufacture. Whereas Plexiglas® G cell cast acrylic sheet, when heated uniformly to forming temperatures, will shrink about 2 percent in length and width, and will increase in thickness by about 4 percent.

The forming temperature range of Plexiglas® MC acrylic sheet is 275°F to 350°F. The recommended forming temperature is 325°F. At this temperature, the material has good extensibility and will vacuum thermoform to detail that is adequate for most applications. Forced forming methods such as plug and ring and free blowing are best performed at this temperature also. The higher forming temperatures should be used only when maximum vacuum detail is needed.

Heating cycle times for Plexiglas® MC acrylic sheet in a circulating-air oven are the same as for Plexiglas® G cell cast acrylic sheet—one minute for each 10 mils (0.010 inches) of material thickness. For example, the approximate heating time in a circulating-air oven set at 325°F for 3 mm (0.118 inches) thick Plexiglas® MC acrylic sheet is 12 minutes. The heating cycles for acrylic sheet heated by infrared heaters are considerably less than for heating in a circulating-air oven.

Parts formed from the sheet should be cooled to approximately 140°F before being removed from the mold. Cooling time and total cycle time depend on the sheet thickness, part configuration, mold temperature and forming technique used. Overall cycle times for Plexiglas® MC acrylic sheet are similar to cycle times for other thermoformable sheet materials.

FORMING TEMPERATURES & CYCLES

Forming temperature for Plexiglas® acrylic sheet must be carefully controlled within the forming range (see 30-Second Modulus Curves—Graph 1).

Excessively high temperatures may cause degradation of the sheet. Excessively low temperatures may cause excessive stresses leading to crazing in service. The optimum temperature at which Plexiglas® acrylic sheet should be formed will vary according to the method of forming and the ultimate shape desired (Table 1). In specific applications the optimum forming cycle should be determined by trial.

Plexiglas® acrylic sheet should be heated to temperatures from 290°F to 350°F. These are sheet temperatures. The formability of hot Plexiglas® G acrylic sheet changes little within these temperature ranges. However, the formability of Plexiglas® MC acrylic sheet changes greatly. Higher temperatures may reduce the tear resistance of the sheet and may also impair its physical properties without visible change in appearance and before bubbling occurs on the surface.

Further, if the Plexiglas® acrylic sheet is too hot, the surface will be softer and more likely to pick up fingerprints, glove marks, specks of dirt and imperfections (called mark-off) from the form. These marks may require extensive polishing to remove. Mark-off can be removed from Plexiglas® G acrylic sheet by reheating.

Thinner material must be heated to higher temperatures than those used for thick stock because the thin material cools more rapidly.

In some cases, the sheet may be heated above the required minimum forming temperatures, removed from the oven, and the surfaces allowed to cool slightly before they come in contact with the mold. In this procedure, the center of the sheet remains hot enough that excessive stress is avoided, but the surfaces are sufficiently cool to minimize mark-off.

Note: Never use a narrowly focused air blast, as this process can chill small areas of the heated sheet, thus creating stress and warpage. Large fans are sometimes employed for cooling, but care must be exercised to ensure that cooling is uniform and even.

The temperatures recommended in Table 1 are intended as a guide in establishing proper forming conditions. Variations for the different methods are based on average time requirements for handling the Plexiglas® acrylic sheet between the oven and the forming apparatus and for clamping the sheet and completing the forming operation.

Sufficient but not excessive time should be allowed for the sheet to be heated throughout to forming temperature. This time will depend on oven temperature, air velocity in the oven and the sheet thickness. In general, at least one minute heating time should be allowed for each one hundredth inch of thickness of the Plexiglas® acrylic sheet, when both surfaces are exposed to the circulating hot air, e.g., a sheet 0.236 inches thick should be heated for approximately 24 minutes. Times can be adjusted as experience dictates.

Rather than control the oven temperature for each different thickness of sheet, it is general practice to control the oven at the highest temperature required for any Plexiglas® acrylic sheet being heated, then control the temperature of the sheet by the length of time it is kept in the oven.

Excessive exposure times at forming temperatures should be avoided as this can cause edge degradation and/or surface degradation (bubbling or yellowing, or both) of the sheet. For example, with Plexiglas® G acrylic sheet, bubbling can occur at 350°F after five hours, and at 400°F after only about 15 minutes.

Recommended Sheet Temperatures* for Forming Plexiglas® Acrylic Sheet

| Type of Forming | Plexiglas® Acrylic Sheet Regardless of Sheet Thickness | |
|--|---|------------|
| | G | MC |
| Two-Dimensional (Drape) | 290°-310°F | 275°-290°F |
| Air Pressure Differential Without Form (Free Blown) | 350°F | 325°F |
| Stretch (Dry Mold Cover) | 320°F | 310°F |
| Air Pressure Differential With Male Form (Snapback) | 340°F | 325°F |
| Air Pressure Differential With Female Form | 350°F | 325°F |
| Stretch with Male Form (Plug & Ring) | 350°F | 325°F |

TABLE 1

*Caution: Do not heat Plexiglas G sheet above 360°F or for more than one hour. Plexiglas® MC acrylic sheet should be heated to required forming temperature and then formed. Do not heat more than the required time.

Time Available for Forming

Heated Plexiglas® acrylic sheets must be completely formed before their surface and internal temperatures drop below 275°F. Unless forming is completed at or above this temperature, the parts will be cold formed with resultant inherent stresses within the material.

These stresses cannot be removed by annealing unless the annealing takes place at temperatures high enough to cause significant deformation of the part.

The time available for forming heated Plexiglas® acrylic sheet before it cools below the minimum forming temperatures (Table 2) depends on the sheet thickness and temperature, air temperature in the fabricating shop and mold material and temperature. To minimize the time required to form the heated sheet, place the forming apparatus near the heating oven and use conveyors, quick-acting clamps and other time-saving devices.

If it is not possible to form the sheet within the time limits given in Table 2, it may be necessary to enclose the forming apparatus and maintain the area within the enclosure at a higher ambient temperature. Ambient temperatures to 120°F may double or triple the time available for forming.

Another method of increasing the time available for forming is to keep the forming molds warm. This can be done by using a properly spaced bank of infrared lamps focused on the molds or by using metal molds that are cored for circulating warm water or oil. Metal molds cool the Plexiglas® acrylic sheet faster than those made of wood, plaster or the thermosetting resins; hence, it is more important that they be kept warm during forming. The mold should not be allowed to get too hot or the sheet will require longer cooling times. Best results are usually obtained with a mold temperature of about 150°F to 170°F for Plexiglas® G acrylic sheet, and 10 degrees lower for Plexiglas® MC acrylic sheet.

Slow Cooling

After the Plexiglas® acrylic sheet has been formed, it should be allowed to cool slowly and uniformly. Slow, uniform cooling will help minimize internal stress and often results in truer contours, particularly in thick parts. Many fabricators cover a formed part with a soft, heavy blanket for these reasons.

The parts should be cooled to a temperature of 150°F to 170°F for Plexiglas® G acrylic sheet and 10 degrees lower for Plexiglas® MC acrylic sheet before removing it from the form. Otherwise, the material will tend to go back to its flat sheet shape. On the other hand, formed parts should not remain on the form till completely cooled or cracking may occur. Definite heating, forming, and cooling time cycles should be established for production of uniform parts.

Reforming

Properly formed acrylic parts will retain their shape if kept below 180°F for Plexiglas® G acrylic sheet and 10 degrees lower for Plexiglas® MC acrylic sheet. If exposed to higher temperatures, they tend to revert to the original flat sheet form. This property, called elastic memory, prevents forming acrylic parts in several stages as in sheet metal pressing, but permits the fabricator to reheat and reform the sheet if he makes an error in forming. When reforming, the sheet should be heated for flattening and reforming at the same time to keep at a minimum the total time the sheet is exposed to oven temperature (see Caution noted under Table 1).

Maximum Time Available for Forming Plexiglas® Acrylic Sheet*

| Plexiglas® Acrylic Sheet Thickness (in) | Plexiglas® Acrylic Sheet Temperature | Maximum Available Forming Time (Minutes) | |
|---|--------------------------------------|--|-------|
| | | 75°F | 120°F |
| .060 | 360°F | 0.5 | 1.3 |
| .060 | 320°F | 0.4 | 1.0 |
| .060 | 285°F | 0.1 | 0.3 |
| .118 | 360°F | 0.8 | 1.5 |
| .118 | 320°F | 0.5 | 1.0 |
| .118 | 285°F | 0.1 | 0.3 |
| .236 | 360°F | 1.5 | 4.0 |
| .236 | 320°F | 0.6 | 1.5 |
| .236 | 285°F | 0.1 | 0.3 |
| .472 | 360°F | 2.5 | 6.5 |
| .472 | 320°F | 1.3 | 2.0 |
| .472 | 285°F | 0.2 | 0.5 |

TABLE 2

*In still air before it cools below minimum forming temperature, 275°F for Plexiglas® G and Plexiglas® MC acrylic sheet.

FORMING EQUIPMENT

Presses

The amount of pressure needed to form Plexiglas® acrylic sheet is much less than that needed to form metal. Presses with a capacity of one ton per square foot of platen area are adequate for forming, including corrugating.

The following rule of thumb can be used to calculate the total force in pounds required to form the average sign face by the plug and ring method: Calculate the perimeter of the basic shape and all interior shapes in inches and multiply the total by 30.

Vertical presses may have (a) a fixed lower platen and a moving upper platen or (b) moving lower and upper platens. Horizontal presses in which the platens move on a horizontal plane are also available. Such presses may be operated by air or hydraulic cylinders that have a stroke of at least 18 inches. (The stroke should be three times the maximum depth of draw.) Platens should have a steady rate of travel of from 5 to 15 feet per minute without chatter. They should be rigid and not deflect more than $\frac{1}{8}$ inch when loaded to capacity.

Clamping Rings and Clamps

Some means should be used for holding the edges of the sheet against the form during forming and cooling. For very simple shapes, rubber bands can be fastened to the form and snapped over the edges of the formed Plexiglas® acrylic sheet. For more complicated shapes, a clamping ring is made to fit the contours of the form. The clamping ring is brought to bear on the edges of the sheet to hold it in place. The ring should be hinged or located by guide pins on the form so that it will always be in correct position in relation to the form, allowance being made for the thickness of the sheet. The ring may also be used as a template of the finished part so that when the plastic is cool, the "trim line" may be scribed while the part is on the form. The Plexiglas® acrylic sheet should not be scribed until it has cooled since the material contracts during cooling.

Figure 5 shows several different types of clamps and clamping rings that can be used to hold the Plexiglas® acrylic sheet during forming. The surface of the clamping ring that contacts the hot Plexiglas® acrylic sheet should provide a nonslip grip. The clamp faces can be surfaced with a variety of materials such as coarse

FIGURE 5

Types of Clamps and Rings for Forming

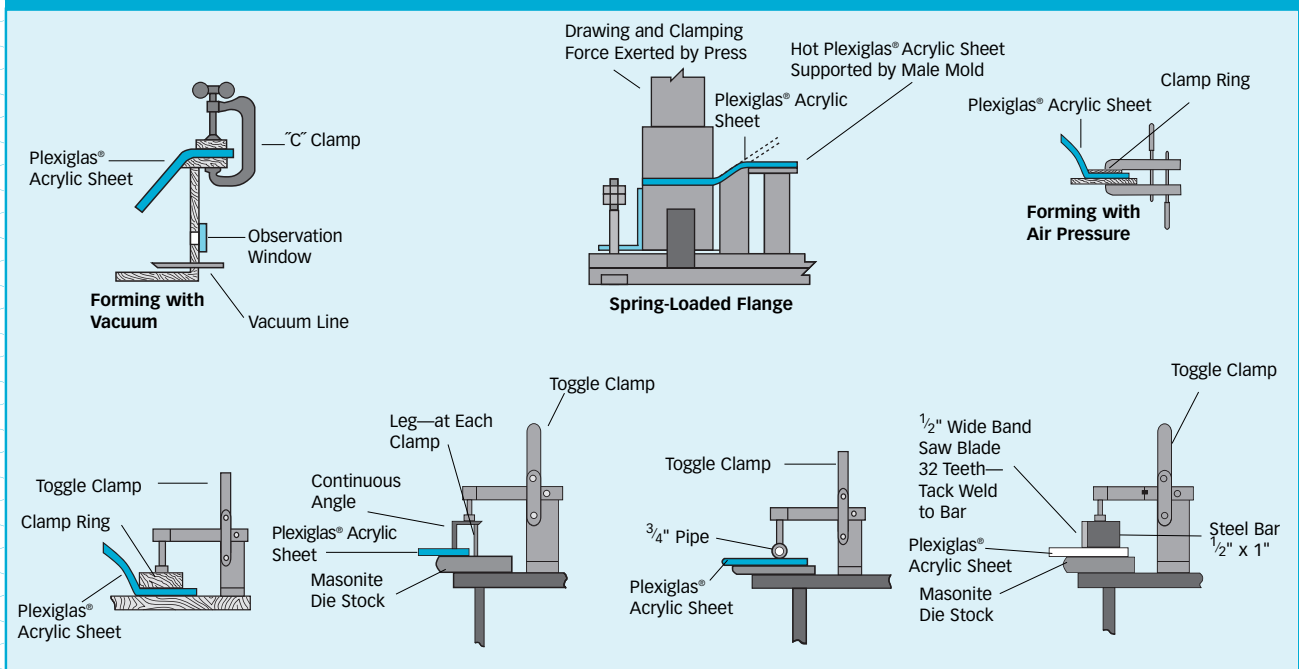

sandpaper, ping pong paddle rubber or perforated metal. The choice of clamping method will usually depend on the number of parts and rate at which the parts must be formed. If only a few parts are to be formed, wood clamps or "C" clamps may be used. For high production rates, toggle clamps or air cylinder actuated clamping rings are used. Forming presses and clamping fixtures may be combined in many different ways to meet the need for versatile forming equipment or specialized devices capable of high production rates. Forming equipment may be constructed from readily available parts and materials to suit any requirement. A few typical designs are discussed below.

Double-action presses that use air or hydraulic clamping and forming cylinders are illustrated in Figure 6. Cylinders are conveniently mounted on a frame constructed of steel I-beams. The forming cylinder, fitted with the mold, may move up or down; if the motion is down, a removable support should be provided for the heated Plexiglas® acrylic sheet to prevent the sheet from draping into the cavity before the mold descends. If the forming cylinder moves up, the mold supplies support for the heated sheet.

FIGURE 6
Double - Action Presses

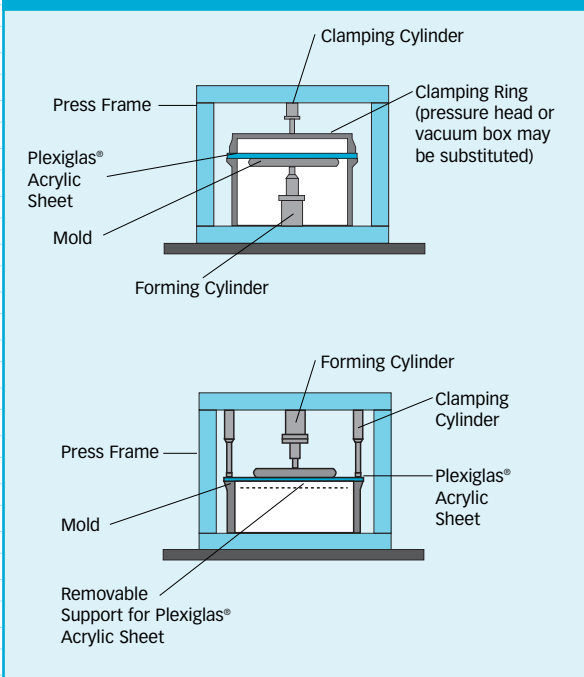
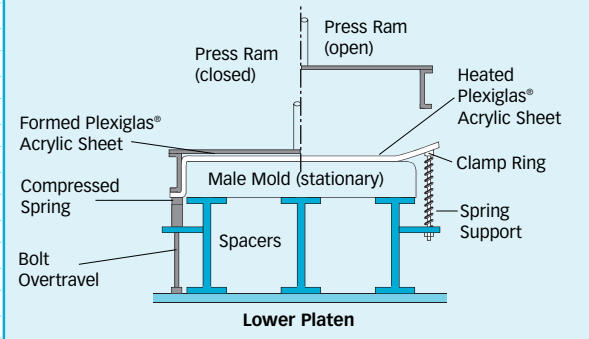
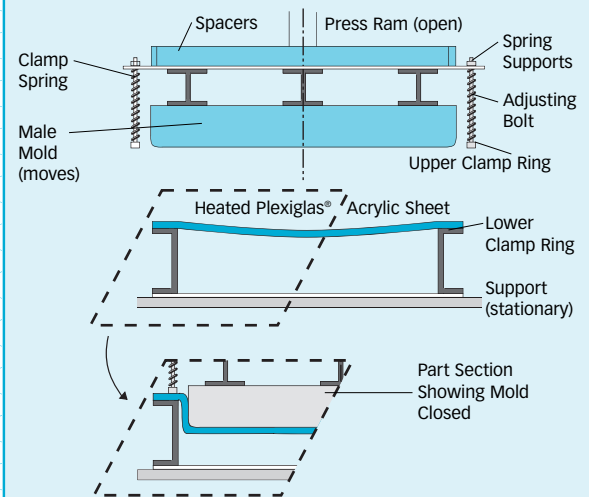

FIGURE 7
Spring-Loaded Clamp for Forming Plexiglas® Acrylic Sheet



Typical spring to allow up to 6" depth of formed part
 1 1/2" pitch dia., .093 dia. spring wire
 22 working coils, both ends flattened & ground
 12" free height
 Springs spaced 6" center to center around edges



Precompress all springs 3" with adjusting bolts to produce approximately 10 lbs./running inch initial clamping force. Clamping pressure increases as male mold closes to form the Plexiglas® acrylic sheet. Press must have enough total force to form the part plus compress the clamping springs.

A number of cylinders may be required to develop the clamping pressure required to hold the Plexiglas® acrylic sheet without slippage. Alternatively, individual clamping cylinders may be replaced with a clamping ring. Double-action presses can also be adapted to forming by air pressure differential by replacing the clamping ring with a ruggedly constructed vacuum or pressure box.

Separate clamping cylinders are not essential. Another widely used design shown in Figure 7 makes use of spring-loaded clamping rings that are actuated by the single press ram. The male mold may be stationary, providing a support for the heated Plexiglas® acrylic sheet, or it may be driven into the sheet by the ram. The surfaces of the clamping ring should be serrated to prevent slippage of the sheet. The press must have enough total force to compress the clamping springs as well as form the sheet. The springs should develop a clamping force of approximately 10 pounds per running inch.

The sketches in Figure 7 show spring-loaded clamps on a vertical press but they can also be used to good advantage with a horizontal press.

An especially versatile and inexpensive forming fixture for vacuum or pressure forming is shown in Figure 8. The device consists of an adjustable clamping frame constructed of wood, Masonite die stock and iron pipe mounted on a press over a vacuum/pressure table which serves as the lower platen.

FIGURE 8

Adjustable Frame and Vacuum/Pressure Table

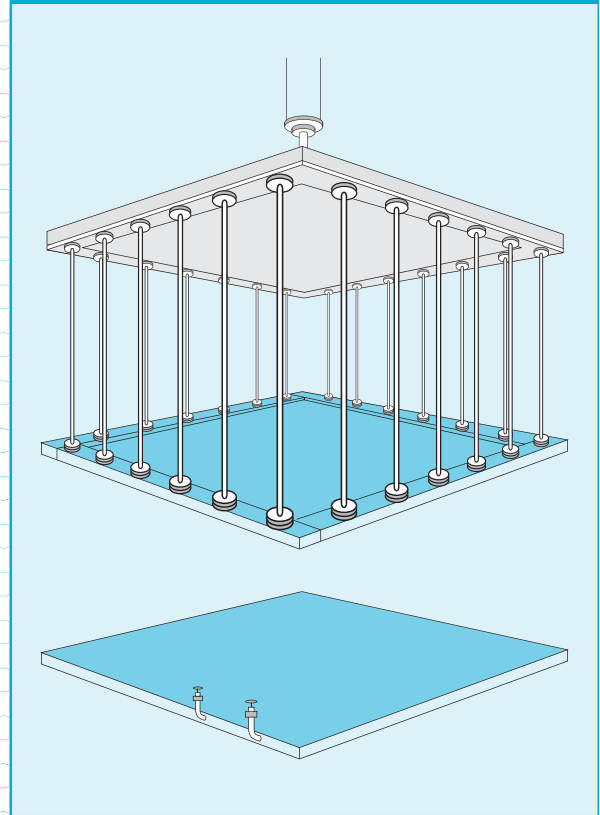

The construction of the vacuum/pressure table is illustrated by the sketch, Figure 9. A perforated plywood face (pegboard) is sealed to a box frame, supported by spacer blocks. A vacuum outlet is attached to the side of the frame and a compressed air line is brought through the plenum to the underside of the perforated board.

An important feature of the design of this forming fixture is the ease with which the size of the clamp can be adjusted to form parts ranging from about 12 x 12 inches to several feet in length and width. The front side of the frame is stationary, the left side can slide forward, the right side moves to the left and the back can move in both directions, so that the clamp can be set to form any size square or rectangle within the outer dimensions of the press. In Figure 8, the clamp is shown extended to full size; in Figure 10, the sketch shows the clamp set to form a small square. The illustration, Figure 8, shows the forming fixture installed on a self-leveling press; if a conventional press such as that in Figure 10 is used, a supporting pipe should be installed in the right rear corner, as shown, to keep the load in balance when small parts are formed. The supporting pipes are threaded with right- and left-hand threads on opposite ends so that the clamp may be leveled simply by turning the pipes.

To form parts such as skylight domes with compressed air, the vacuum/pressure table is first covered with kraft paper to block off the vacuum holes, then covered with light flannel to diffuse the air and prevent chilling of the heated sheet when it is clamped in the press. A dome of any desired height within the daylight opening is formed by admitting compressed air as shown in Figure 11. The front side of the clamping frame is hinged at top so it may be raised to facilitate removing the part after forming.

Vacuum forming is carried out in a similar manner using a perforated mold on the vacuum/pressure table. Vacuum holes outside the area of the piece to be formed are covered with kraft paper. Heated Plexiglas® acrylic sheet is clamped to the mold, and a vacuum is drawn, forming the sheet.

The convenient design of this adjustable forming fixture may be adapted to any specialized forming operation. For example, if it is to be used only for forming shallow parts, the daylight opening may be much smaller than in the model illustrated.

FIGURE 9

Vacuum/Pressure Table

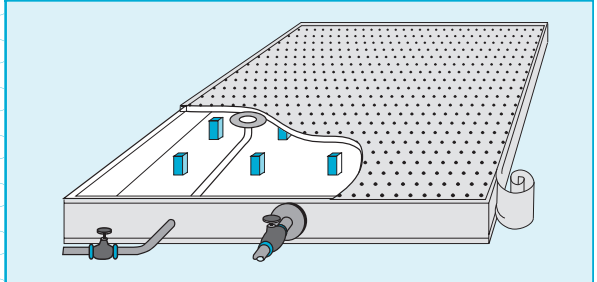

FIGURE 10

Adjust to a Small Size Part

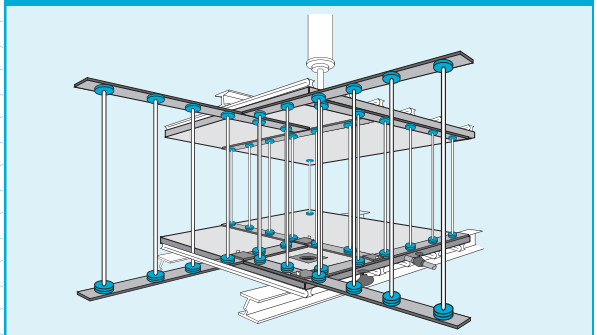
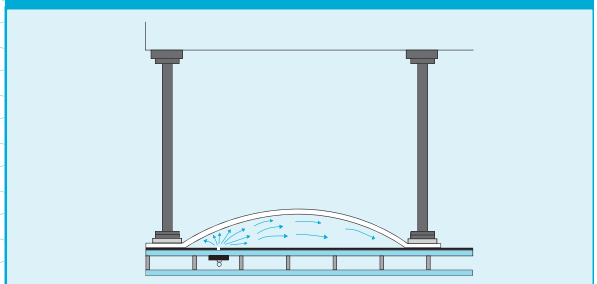

FIGURE 11

Free Blow Forming



Vacuum Forming Equipment

The equipment required for vacuum forming consists of a source of vacuum, an accumulator tank, piping, valves and fittings, and the vacuum pot or chamber in which the actual forming is done (Figure 12).

The vacuum chamber is generally made of steel plate, all seams being welded and airtight. The chamber should have a flange around the edge for attaching clamping rings and should be as small as the part will permit to minimize the amount of air, that must be removed during forming. The completed part should be at least 2 inches from the inside of the vacuum pot to prevent touching and to prevent uneven heat transfer from the hot sheet to the cool tank wall.

If only a few pieces are to be made, the chamber can be built of heavy plywood or Masonite® die stock on a frame of wood two-by-fours. The joints are sealed by a caulking compound applied to all edges before assembling. Any gun or knifing compound can be used and will maintain the seam, even though there is a certain amount of movement of the joints as the pressure within the pot is reduced. Such movement often cracks a glued joint and causes leakage. For additional sealing, masking tape can be applied to the outside of all seams and Spraylat® or a similar material may be brushed on the outside.

Clamping rings can be made of plywood, rigid phenolic laminate or Masonite die stock, with a center hole cut to the desired shape. Interchangeable clamping rings will permit production of a variety of parts on a single vacuum chamber. Metal rings should not be used unless they are temperature controlled, because they chill the Plexiglas® acrylic sheet too rapidly. Plywood may be used in some cases if mark-off in the flange area is not objectionable. Hardwood plywoods give better results than softwood plywoods.

When the detachable rings are used, a tubular gasket or "O" ring can be applied between the metal flange and the removable ring. The greater the pressure on such a gasket, the tighter the seal.

In practice, the hot Plexiglas® acrylic sheet is clamped between the detachable ring and a hold-down ring, by any of the various means suggested. This second ring may be knurled or scored to prevent the sheet from slipping. Often the edge of the detachable ring is beaded to make an airtight seal. Such a seal is important not only for preserving the vacuum, but also to avoid drawing in cool air, which may chill the sheet unequally. A small leak can make the difference between the production of good and bad parts.

A vacuum pump, driven by an electric motor that will handle 25 to 50 cubic feet of air per minute at 27 inches of mercury, is satisfactory for forming all but the largest parts. Steam, water, air venturi or ejector valves can also be used. Whatever source is used, it should maintain at least 22 inches of mercury at the rated volume to make the system most useful.

FIGURE 12

Equipment for Vacuum Forming

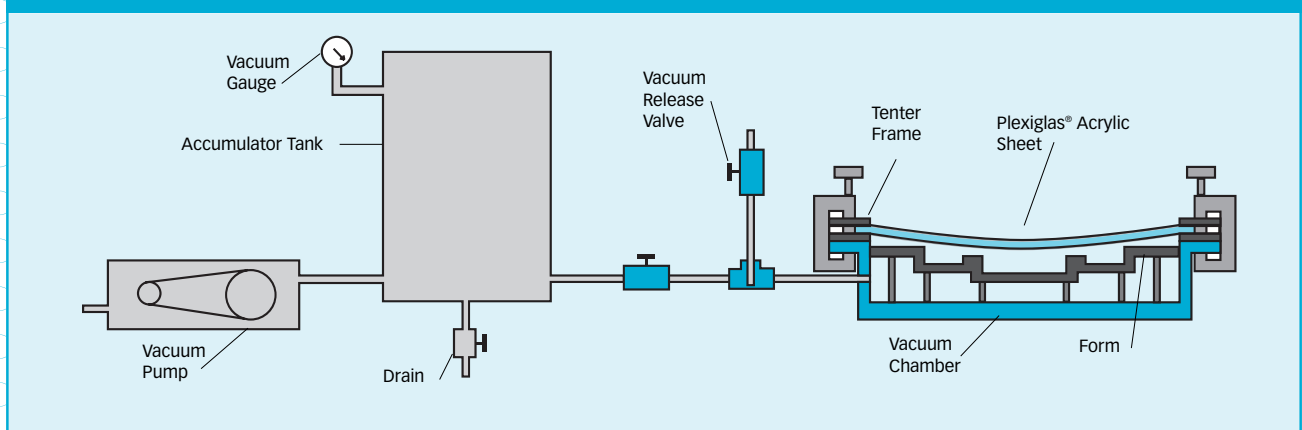

The vacuum system should include an accumulator tank to prevent fluctuations in air pressure during forming. Galvanized steel domestic hot water tanks, or any tank able to withstand external pressures of 15 psi, are recommended in capacities of 30 to 100 gallons. The larger sizes give extra capacity at little extra cost and permit greater flexibility in the system. The vacuum pump should be capable of pumping a volume of air per minute (at minimum of 22 inches of mercury) approximately twice the volume of the system, including the accumulator tank and the vacuum pot. The accumulator tank should be fitted with a drain.

Standard steel piping and valves of one inch diameter or larger are normally used. At least one section of the piping between accumulator and forming chamber should be made of flexible metal reinforced hose so that the chamber can be moved or the connection changed easily. Short, large-diameter pipes and valves reduce losses and make a more efficient system.

A pipe from the vacuum chamber is connected with a standard pipe tee. One side of the tee is connected through a valve to the vacuum line; the other, through to a second valve, is open to the atmosphere. The pressure, and hence the rate and depth of draw, can be accurately controlled by adjusting the two valves.

This control may be manual or automatic (Figure 13). In one mechanical system, the Plexiglas® acrylic sheet, as it is being formed, touches a micro-switch which activates a solenoid. This solenoid operates an air line controller, which in turn, controls the modulating valve on the vacuum line. In another system, the sheet, as it is being drawn, interrupts a beam of light focused on a photoelectric cell. The change in current in the cell operates a solenoid valve, through relays to open and close the vent line on the vacuum pot. A high-lift or needle-valve is adjusted on the vacuum line so that the volume of air being drawn from the vacuum pot is balanced by the volume of vented air. In this way the correct rate of draw and depth is maintained.

FIGURE 13

Typical Vacuum System with Automatic Control

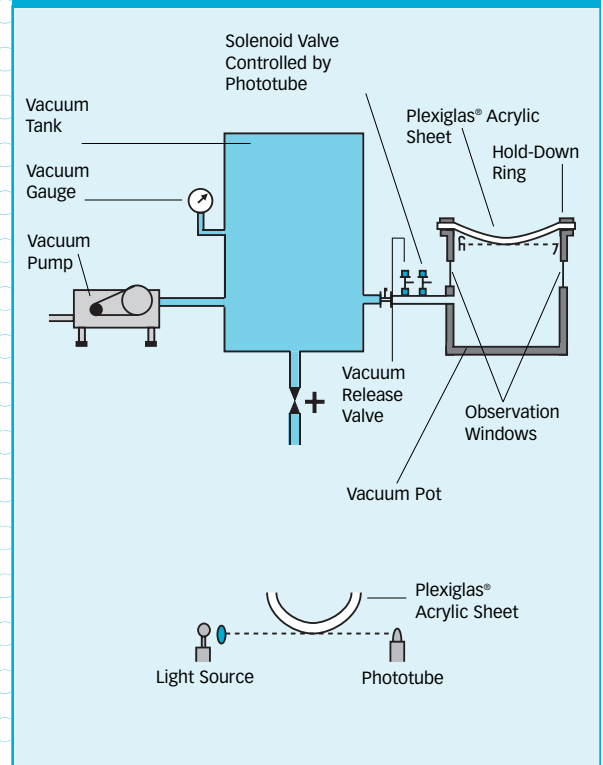

FORMS FOR PLEXIGLAS®

ACRYLIC SHEET

Contour Tolerances and Effects of Forming

Contour tolerances of plus or minus $\frac{1}{8}$ inch can be maintained in many forming operations, but for free-blown sections, particularly in large sizes, tolerances of up to plus or minus $\frac{1}{2}$ inch may have to be allowed. The reduction in thickness caused by deep drawing will tend to lighten the color or translucency of colored Plexiglas® acrylic sheet, so that the color of the drawn pieces may not match the original color of the flat sheet, especially where the part is viewed with transmitted light. This graduation of color can be used to advantage in such applications as lighting fixture shields.

Shrinkage Allowances

When the final dimensions of the formed parts are critical, forms must be built sufficiently oversize to allow for shrinkage when the parts cool from forming temperature to room temperature. A shrinkage allowance of approximately $\frac{3}{32}$ inches per foot should be made in designing female forms for Plexiglas® acrylic sheet and about $\frac{1}{16}$ inch per foot for male forms. Remember it is better to remove too little material from a form than too much. Also, surfaces of the forms should extend beyond the trim line. This permits the use of slightly oversize sheet, which simplifies handling and compensates for the slight tendency of the plastic to curl away from the form and flare at the edges.

Materials for Forms

Since most drape forms for Plexiglas® acrylic sheet are not subjected to great pressure, they may be constructed of wood, plywood, sheet metal or sheet laminates bent over wooden or metal formers. Except for long production runs, forms need not be made of metal or materials generally used for sheet metal forming. Either convex or concave forms can be used, but usually the convex or male shape is preferred (Figure 16). Forms for compound three-dimensional or deep-drawn shapes are more difficult to make, but are made the same way as patterns for castings.

Molds for thermoforming Plexiglas® MC acrylic sheet may be constructed of most common mold materials. Plexiglas® MC acrylic sheet will reproduce the mold detail extremely well, however, so it will also reproduce any mark or defect on the mold surface. For applications in which surface quality is important, the mold surface must be well finished. Tooling plastic resin and cast metal alloys make the best thermoforming molds.

Wood Forms

The best woods for forms are kiln-dried hardwoods such as birch or cherry. Well-dried soft woods, such as white pine, poplar or Philippine mahogany, may also be used if sound and free of knots. All woods must be sealed to prevent changes in shape and dimensions, which occur with atmospheric changes. Synthetic resins, high-temperature varnish or casein should be used because shellac or regular varnish will soften at forming temperatures. Wooden forms should be made so that side grain of the wood is on the surface throughout, since end grain may produce distortions in the finished pieces.

Resin Impregnate Forms

Masonite die stock, a compressed, lignin-bonded material, cloth or paper-base phenolics and Impreg or Compreg, special resin-impregnated woods, can also be used for forms for Plexiglas® acrylic sheet. These materials can be built up, laminated, and finished to produce excellent molds with polished, grainless surfaces which will resist wear and will not be affected by normal moisture changes.

Metal Forms

Forms can be made of cast metal or fabricated from plate and bar stock. Some low-melting alloys can be cast to good finish for small forms. These alloys are especially convenient for model work. Aluminum, bronze, brass, and high-melting alloy molds can be cast by regular foundry techniques. They should be carefully finished because pits, blowholes, and other surface defects will be reproduced in the formed acrylic parts. Provision should be made to control the temperature of metal forms, since metal lends itself well to coring/heat transfer (unlike most other mold materials).

Cast Forms

Casts of various materials can be made from the original wooden form. Allowances for the shrinkage of the casting as well as for the contraction of the Plexiglas® acrylic sheet must be made when building the original. If the final form will require finishing to obtain the smooth surface necessary for forming Plexiglas® acrylic sheet, allowance must also be made for the material to be removed during finishing.

Gypsum Forms

Satisfactory forms can be cast from high-strength gypsum products. Specific instructions for their use are supplied by the manufacturers and should be followed exactly.

No finishing is needed if a good smooth surface is applied to the original pattern and the casts are properly made. Gypsum forms should be made with a hollow shell from 2 to 4 inches thick, not solid (Figure 14). They should be reinforced with steel rods and wire-mesh welded into a shape to take any tension or bending stresses. Use steel strips around the edges and at clamping points to strengthen and stiffen the form and prolong its life.

FIGURE 14

Gypsum Form

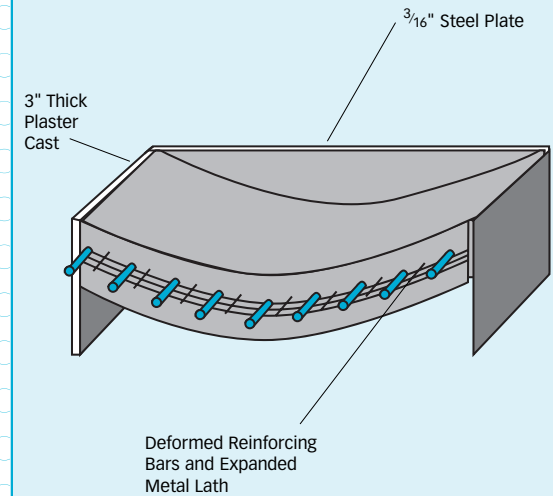

Resin Forms

Very good forms can be cast from phenolics and other thermosetting resins. The dimensions of phenolic molds should be checked from time to time.

The form should be cast from a carefully finished female mold, according to directions supplied by the manufacturer. Polyester and epoxy glass reinforced lay-ups can be used for either male or female molds. A smooth gel coat on the surface against which the Plexiglas® acrylic sheet is to be formed will help reduce mark-off. Resin forms may be more expensive than gypsum forms, but provide a smoother, tougher surface when properly made from the correct materials.

Surfaces of Forms

The surfaces of forms should be free of waves and other variations in contour that might cause optical distortions in the finished part. Surfaces of drape or snapback forms are usually covered with soft cotton flannel cloth, flannelette, velvet, or billiard felt. The nap of these cloths helps prevent mark-off which might otherwise result from small dirt particles or irregularities in the surface of the mold. For covering three-dimension forms use suede rubber or flocked rubber sheeting which can be stretched to the contour of the form.

While the fabricator is generally interested in minimizing mark-off, very attractive designs can be intentionally embossed in the plastic surface during forming of decorative parts. Coarsely woven cloths, wire meshes, patterned metals, and the other materials applied to the surface of the form can impart pleasing texture to the Plexiglas® acrylic sheet and enhance the appearance of a formed part.

Forms used for translucent Plexiglas® acrylic sheet should contact only the inside surface since mark-off does not show on the outside. Where female portions of molds are required to obtain the desired shape, they should be relieved so only the perimeter contacts the hot sheet. An important exception is translucent lighting fixture pans and shields. The exterior surface of the pans can be made nonspecular by forming against a sandblasted aluminum mold or similar form. (See Surface Embossing on page 33.) Pre-painted Plexiglas® acrylic sheet should be formed so that the non-painted surface contacts the mold whenever possible.

Grease-Covered Forms

Felt mold covers saturated with grease can be used to minimize mark-off and eliminate objectionable optical distortion. It is not recommended to try to form Plexiglas® MC acrylic sheet in this manner. To prepare a grease form, cover the mold with a felt blanket, heat the covered mold and work grease into the felt until it is thoroughly saturated.

In use, the mold must be kept hot almost to the point where the grease runs. The temperature of the Plexiglas® acrylic sheet should be higher than when using uncovered forms. The best parts are produced when the form is heated to 170°F for Plexiglas® G acrylic sheet, and the surface of the grease is heated to approximately the sheet temperature. It is usually necessary to apply a fresh layer of grease after forming each part because much of it is removed by the Plexiglas® acrylic sheet. The form should be mounted below the sheet to avoid dripping grease on the material while the sheet is being clamped in place.

After forming, wash the grease from the formed parts with kerosene, hexane or aliphatic naphtha. Do not use chlorinated or aromatic hydrocarbons, lacquer thinners or other solvents that are harmful to Plexiglas® acrylic sheet.

A water-emulsifiable grease may be used. This may be washed off with water.

FORMING METHODS

Preparation of Sheets for Forming

Hot Plexiglas® acrylic sheet can be handled much like a sheet of pure gum rubber and approximately the same force is required to stretch it. For making simple shapes, especially when thick sheet is used, the weight of the material is often sufficient and only if considerable stretching is required should much pressure be applied. Most three-dimensional shapes may require the use of vacuum, air pressure, or mechanically or hydraulically actuated forms or combinations of these. Forms should be kept clean and brushed off before each piece is formed. They should also be stored carefully when not in use to protect them from denting, chipping, or warping. Such defects will show up in the Plexiglas® acrylic sheet on forming.

Before heating the Plexiglas® acrylic sheet, cut somewhat oversize, remove the masking paper. Any specks of adhesive that adhere to the sheet can be removed by dabbing with the gummed side of the masking paper. If the sheets are dusty or dirty, they should be washed with soap and water and rinsed well. The sheet should be dried thoroughly by blotting with soft cotton cloth. Otherwise, solids dissolved in ordinary tap water will bake into the plastic surface when the material is heated. Operators should wear soft cotton gloves to avoid fingerprinting or scratching the sheets and should grip it only in the clamping area.

Two-Dimensional Forming

Cold Forming

Plexiglas® acrylic sheet can be bent while cold to simple shapes by springing the material into a curved frame. The radius of the curvature should be a minimum of 180 times the thickness of the sheet for Plexiglas® G acrylic sheet. Plexiglas® MC acrylic

Cold-Forming Minimum Radius of Curvature

| Thickness (in) | Minimum Permissible Radius of Curvature (in) | |
|----------------|--|-------|
| | G | MC |
| 0.060 | 10.8 | N/A |
| 0.080 | 14.4 | N/A |
| 0.098 | 17.6 | 29.4 |
| 0.118 | 21.2 | 35.4 |
| 0.177 | 31.9 | 53.1 |
| 0.236 | 42.5 | 70.8 |
| 0.354 | 63.7 | 106.7 |
| 0.472 | 85.0 | N/A |

TABLE 3

N/A=Not Applicable.

sheet requires a minimum radius of 300 times the thickness. Table 3 lists the minimum permissible radius of curvature versus Plexiglas® acrylic sheet thickness.

Cold forming Plexiglas® acrylic sheet beyond these limits may result in crazing of the material because of stresses beyond those recommended for a continuous load.

Strip Heat Bending

The simplest method of forming Plexiglas® acrylic sheet along a straight line is to use a strip heater, which heats the sheet to forming temperature so that it can be formed along that line. The method lends itself to the rapid production of simple boxes, picture frames and similar items, but is generally limited to straight line bends. The process is usually used for small parts where the length of the bend is relatively short. Long bends (over 24 inches) tend to bow.

The Plexiglas® acrylic sheet, unmasked along the bend line, is placed over the heating element and allowed to remain until it softens. (See Figure 4.) Excessive heating times should be avoided as the sheet could bubble and degrade.

FIGURE 15

V-Groove Cut Before Heating and Bending

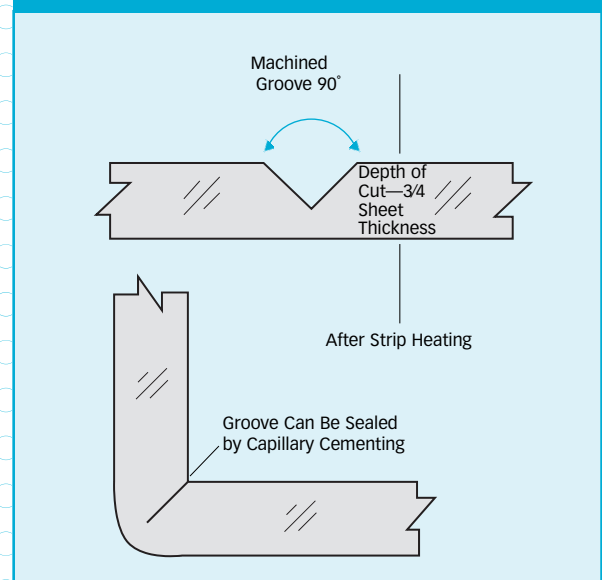

After heating, the Plexiglas® acrylic sheet should be bent to the required shape quickly and held, usually in a fixture, until cool. In production, a number of strip heaters and fixtures can be arranged so as to make several folds in one operation.

Sharper, straighter bends can be made by strip heating if a 90° groove for right-angle bends is machined along the bend line on what will be the inside of the formed part before heating (Figure 15).

Strip heating and bending any thermoplastic induces a high degree of stress into the material, which can result in cracking or crazing. The degree of stress depends upon the length of the bend, width of the heated area, material thickness and the amount of material on either side of the bend. Heating as narrow an area as possible, consistent with good design practice, will minimize overall stress in the part but concentrate it, thereby increasing the crazing possibility. An effective manner in reducing the stress level is to machine a V-notch about halfway through the thickness of the material. The groove is positioned on the inside of the bend, which develops a sharp radius not in accordance with good structural design practice of 2-3 times the material thickness. However, aesthetics (crisp corners and no crazing) often outweigh structural considerations in non-critical applications. No cement should be applied to the V-notch after bending.

Drape Forming

Drape forming is used for two-dimensional shapes and for mild three-dimensional shapes.

After heating to the proper temperature (Table 1), the Plexiglas® acrylic sheet should be removed from the oven and carefully draped over the form (Figure 16). The edges of the sheet will tend to curl away from the form and should be held against the form by a clamping ring or rubber bands until the part is cool. Most uniform cooling and best contour tolerances can be obtained if the parts are covered with a soft blanket or flocked rubber sheet and allowed to cool slowly. This is most important when close contour tolerances and good optical properties are required in a thick acrylic part.

It is best to use a female drape form, as the part will lay into the mold by the weight of the sheet. This reduces mark-off.

FIGURE 16

Male Drape Form

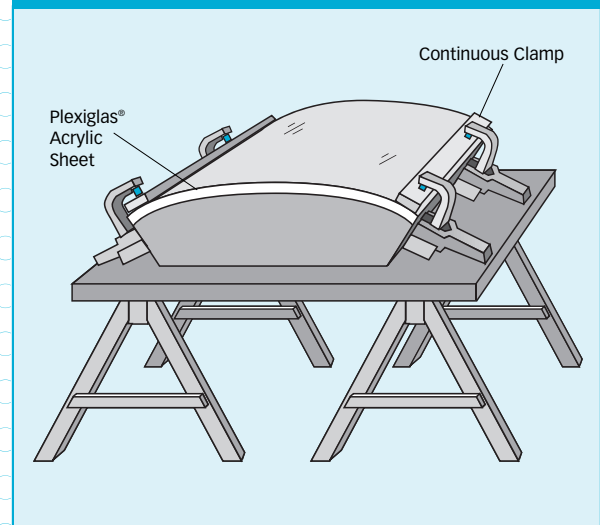

Three-Dimensional Forming

Three-dimensional shapes in Plexiglas® acrylic sheet are formed by stretching the heated material to the required contour. The force required to stretch the sheet can be supplied by manual labor, mechanical pressure, hydraulic pressure, vacuum, air pressure, or combinations of these, depending on the forming method being used.

Free Forming

Free forming is used to form three-dimension shapes entirely by the use of air pressure differentials—vacuum or positive pressures without the use of male or female forms (Figures 17 and 18). Parts produced by this method usually have excellent optical properties.

In free forming, the heated sheet is simply clamped over a vacuum pot or pressure head and drawn or blown to shape. There is no possibility of mark-off since the sheet does not contact any form. Further, when an air pressure differential does the work of forming, the manpower required is reduced, and cooling is relatively uniform because both surfaces of the Plexiglas® acrylic sheet are exposed to air.

FIGURE 17

Free Forming with Vacuum

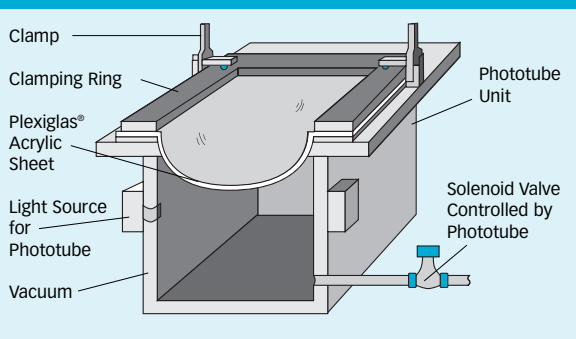
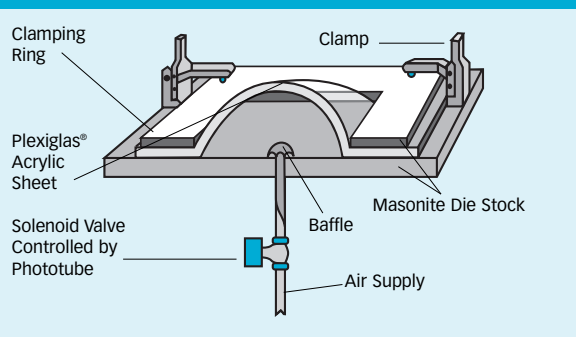

FIGURE 18

Free Forming with Air Pressure



When the opening in the vacuum pot or pressure head is circular, the finished part approximates a section of a sphere for shallow-drawn parts. Since the center of the sheet stretches most, this area thins out first and therefore cools first. The thicker areas around the sides and the circumference continue to stretch since they are still hot. Thus deep draws produce a bulging or fish bowl shape. See Figure 19 for ratio of thickness at the apex to original sheet thickness of blown spherical parts of different depths.

Even if the opening of the vacuum pot is square or triangular, the Plexiglas® acrylic sheet tends toward a spherical shape, since a sphere has the smallest surface area of any shape for any given volume. An analogy is the blowing of soap films through different shaped openings. The resultant blown or drawn shapes are often called “free form” or “natural” shapes.

FIGURE 19

Apex Thickness – Free Formed Spherical Parts

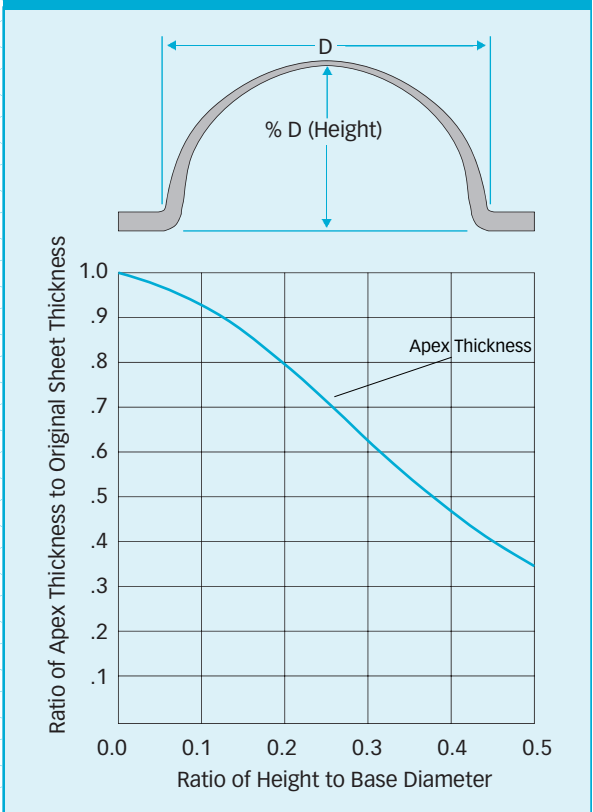

A variety of shapes can be formed by differential air pressure by altering the shape of the pot opening in the third dimension (Figure 20). This can materially reduce thinning out of the sheet, depending on the shape of the part.

The choice between the use of vacuum and positive pressure in forming will usually depend upon the equipment at hand. In general, vacuum forming is preferred because it is safer, easier

to control, and simpler to seal. It is important that the joints in the vacuum pot be sealed against air leaks, which could cause uneven cooling of the part. Sometimes the maximum pressure differential possible with vacuum (14.5 psi maximum) is not enough and positive pressures must be used. Original tooling costs may be lower for positive air pressure forming, as only a pressure head, clamps, and clamping ring are required.

FIGURE 20

Some Free Form Shapes Obtainable with Various Openings

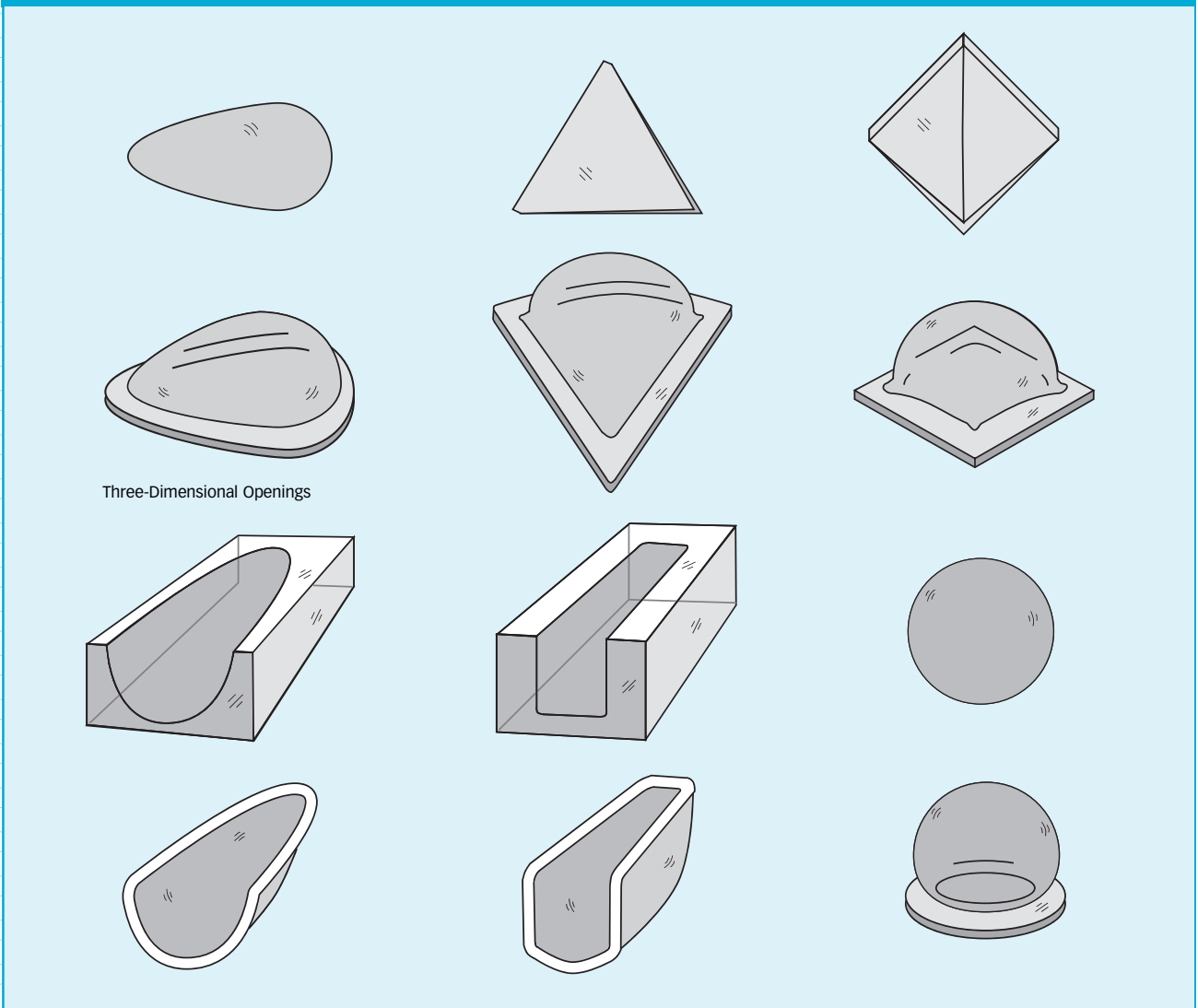

Three-Dimensional Openings

Estimating Pressure Required for Free Blowing or Vacuum Forming

Figure 21 is an alignment chart useful in estimating the pressure required to form various diameters of hemispheres from various thicknesses of Plexiglas® acrylic sheet.

Example:

Problem: Estimate the pressure required to form a 25-inch inside diameter hemisphere from 0.236-inch thick Plexiglas® G acrylic sheet.

Solution: Draw a straight line through the 25-inch diameter on Scale A and 0.236-inch thickness on Scale B. Continue this straight line to intersect Scale C. Read off estimated pressure at the point of intersection of the line and Scale C – 4.8 psi required.

The alignment chart can also be used to estimate the force required for other methods of forming, other degrees of draw, and other than spherical shapes by estimating the diameter corresponding most closely to the desired curvature or by bracketing the least and most favorable geometry of the required part.

Vacuum Snapback Forming

Vacuum snapback forming is often used when the desired part varies from a true surface tension shape. This method is based on the tendency of hot, formed acrylic to return to its original flat sheet form. Plexiglas® MC acrylic sheet has limited snapback capabilities.

Like vacuum forming, snapback forming is done in a vacuum pot (Figure 22). After the heated sheet is drawn into the pot to a larger bubble than the male mold, a male form – which reproduces the inside contour of the desired part – is lowered and locked inside the bubble formed by the Plexiglas® acrylic sheet. Since the sheet is still hot, it has a tendency to resume its flat sheet form. Therefore, as the vacuum is gradually released, the sheet snaps back slowly against the form.

In vacuum snapback forming, all stretching is done by pressure differentials. Less mark-off is produced by this method than by mechanical stretch forming because the Plexiglas® acrylic sheet is stretched before it comes in contact with the form instead of being stretched as it is drawn across the form.

In snapback forming, the Plexiglas® acrylic sheet will not snap back into reverse curves and will not follow rapid changes of contour very accurately. Nevertheless, it is possible to obtain contour tolerances of plus or minus $\frac{1}{8}$ inch or closer in snapback forming compared with plus or minus $\frac{1}{4}$ inch to plus or minus $\frac{1}{2}$ inch for free forming.

An integral flange is formed where the part has been clamped to the vacuum pot. This flange is usually at least $\frac{3}{4}$ inches wide and provides a strong and simple mounting. The contour of the flange can be held to fairly close tolerances, regardless of the tolerances maintained on the rest of the part.

The form should be constructed with a draft of at least three degrees to permit easy removal of the formed part. Small vents should be provided in the male form to permit escape of air that may be trapped between the form and the sheet. Reverse curves can be produced by connecting the vacuum line to vents in depressed areas on the forms.

Vacuum Drawing or Blowing into a Form

This method is also based on air-pressure differentials. The heated Plexiglas® acrylic sheet is clamped directly to the edges of a female form, and the sheet is either drawn down by vacuum or forced down by air pressure into the form.

When the shape closely resembles a “free form” shape, parts formed by this method will have fairly good optical properties. Every part of the sheet comes in contact with the form at approximately the same time, and the pressure can be controlled so that mark-off is held to a minimum.

When the shape is not a “free form” shape, one area of the sheet comes in contact with the form before the other areas are fully drawn, and the pressure at the areas in contact with the form will be great enough to cause surface defects.

If good optical properties are most important, the form can be greased as in “grease forming.” This type of forming is not recommended for Plexiglas® MC acrylic sheet. It is very difficult to attach a felt, greased blanket to the inside of a female mold, and none is ordinarily required. Special polybutene greases, which do not change their viscosity radically with changes in temperature, should be used. The mold should be warmed with electric elements, infrared lamps, steam, or oil to approximately 170°F,

FIGURE 21

Alignment Chart for Estimating Pressure Required to Form Hemispheres from PLEXIGLAS® Cell Cast Acrylic Sheet

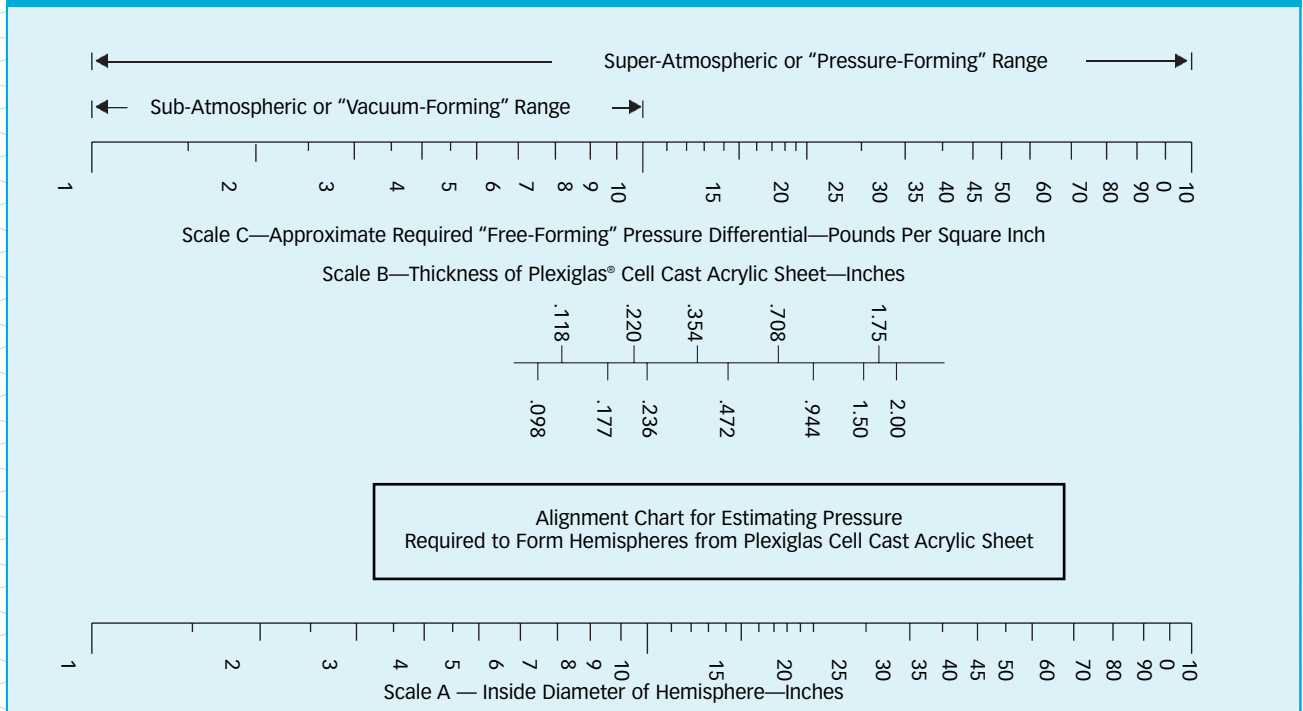
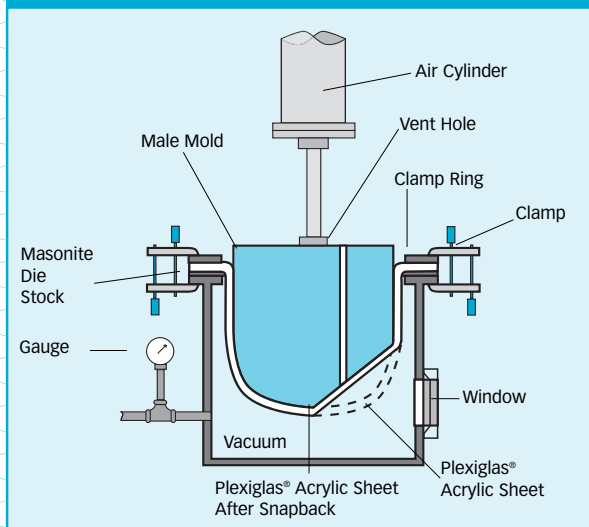

FIGURE 22

Vacuum Snapback Forming



and then coated with a film of grease approximately $\frac{1}{16}$ inch thick. The grease film must be reasonably uniform. It should be smoothed and fresh grease added as needed. The surface of the grease should be heated to as near the forming temperature as possible with infrared lamps just before the heated sheet is clamped in place for forming.

Forms used for vacuum drawing or blowing into a form should be well made of sturdy materials and adequately reinforced. The mold should have a uniform thickness in the forming area to ensure equal deflection under forming pressure or vacuum and constant heat transfer rates. When the mold is greased, positive air pressure is preferred, for vacuum tends to draw entrapped air from the pores of the mold, causing bubbles in the grease layer and distortions in the formed acrylic part. When the mold is not greased, either positive pressure or vacuum may be used. Pressure or vacuum molds should have outlets at the points of deepest draw and should provide a tight seal between flange and Plexiglas® acrylic sheet to avoid air leaks.

Vacuum drawing or blowing into a form is used often for forming parts that differ quite radically from free form shapes, but in which mark-off is not objectionable. In fact, the method can be used to reproduce in Plexiglas® acrylic sheet the mirror image of any pattern or device in the female mold. Very fine detail can be picked up in this way, depending on the amount of pressure used. Close approximations of geometric shapes can also be produced. Corners, of course, will tend to be round, the radius of curvature depending on the pressure used. Sharp corners will tend to thin out because of the greater depth of draw in the corners. Heavy clamping pressure is required when high positive air pressure differentials are used.

To calculate the clamping pressure required to prevent leaks, multiply the pressure required to form the part by the projected area of the part at the clamping ring.

Example:

50 psi required to form

Area: 50 x 60 inches = 3000 sq in

Clamping pressure:

$50 \times 3000 = 150,000$ pounds

Manual Stretch Forming

Manual stretch forming is often used when the compound curvature is not great, when optical distortion is not objectionable, and the number of parts to be made does not warrant setting up mechanical equipment. The sheet is heated to forming temperature and clamps are fastened to the edges, six to ten inches apart (Figure 23).

Holding the Plexiglas® acrylic sheet with these clamps, the forming crew draws the sheet down over the form. For some shapes, one edge of the sheet may be clamped to the form, and the sheet stretched over the form from the other edge. The sheet should be stretched as uniformly as possible. Use slow, steady tension and let the sheet stretch gradually.

After the sheet has been stretched, a clamping ring can be clamped in position around the edges, leaving the crew free to work on other forms.

FIGURE 23

Manual Stretch Forming

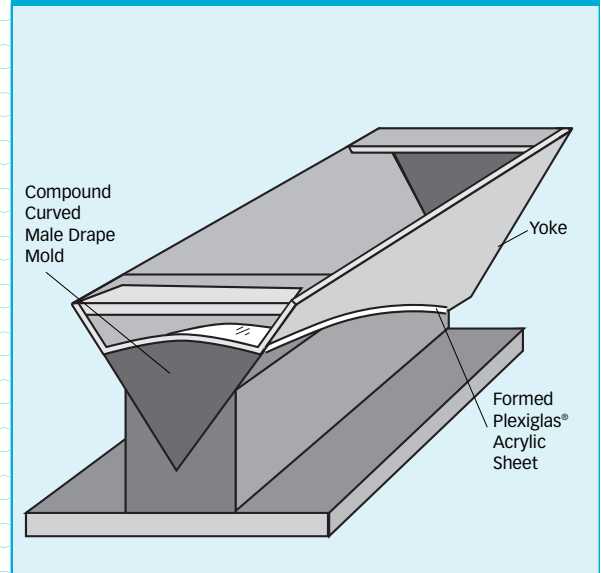

Slip Forming

Plexiglas® acrylic sheet is usually clamped around the edges after heating before it is formed. This puts the whole sheet in tension and it stretches more uniformly and wrinkles are not apt to form. In some cases, in order to obtain a thicker finished part, a predetermined amount of Plexiglas® acrylic sheet is allowed to slip under the clamping ring to reduce thinning out of the sheet.

Wrinkles tend to form outside the ring around the edge of the piece, limiting the amount of material that can be allowed to slip in. When sufficient material has slipped in, the rings are clamped more tightly and the draw is completed. Hot or insulated clamping rings may be used to avoid chilling the material.

Plug and Ring Forming

A modification of stretch forming known as the plug-and-ring method, operates on a principle similar to the familiar embroidery hoop (Figure 24).

The hot Plexiglas® acrylic sheet is clamped over a ring and the center of the suspended material is pushed in with a tapered plug. The ring is made larger than the outside of the male form or plug, with allowance, of course, for the thickness of the sheet.

Plug-and-ring forming usually has the disadvantage of producing excessive mark-off, particularly at the inside corners of the formed part where mark-off is most difficult to remove. This disadvantage is not important for parts where optical properties are not important, nor for forming translucent sheets. Avoid forms with flat surfaces and minimal draft for Plexiglas® MC acrylic sheet because they tend to develop chill lines on the formed part.

Vacuum Assist Plug and Ring Forming

Deeply drawn parts (ratio of width of opening to depth of part is one or less) with little thickness can be made if vacuum is used to assist the draw. The ring support is made into an airtight box to which the heated Plexiglas® acrylic sheet is clamped. Vacuum is applied to draw the sheet to about half the desired depth. The plug is then forced into the drawn sheet to secure the desired shape. When the plug is "home," air is vented into the box to allow the Plexiglas® acrylic sheet to shrink onto the plug. This method produces a more uniform final part thickness than by the method above or by vacuum snapback.

FIGURE 24

Plug and Ring Forming

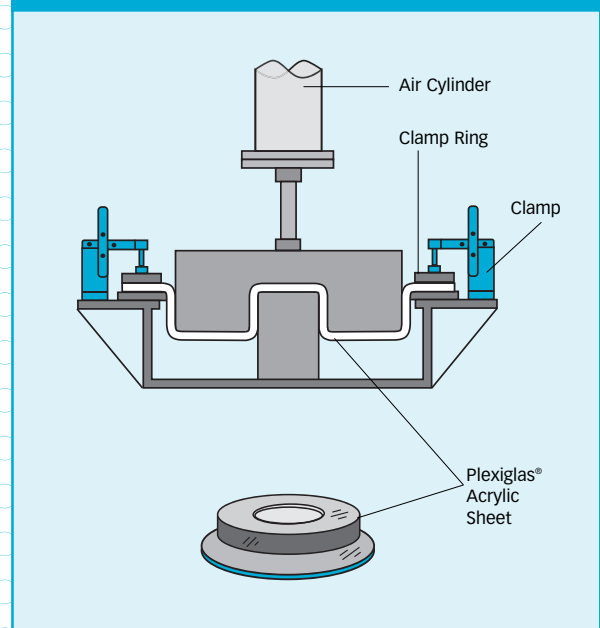

Blowback Forming

One of the main advantages of blowback forming is in the reproduction of complex drawn shapes. Also, deeply drawn parts made by the blowback forming method show less reduction in sheet thickness than when vacuum assist plug and ring forming is used. This method consists of clamping a heated Plexiglas® acrylic sheet between a pressure box and an oversize clamping ring (Figure 25). A male form shaped to the inside contour of the part is then pressed into the sheet to the required depth and locked in this position, thus stretching the sheet. Compressed air at 50 to 100 psi is then admitted to the pressure box, forcing the heated sheet back against the male form. The parts are held in this position by air pressure until the sheet cools and becomes rigid. The forming cycle must be fast enough to ensure that the Plexiglas® acrylic sheet is still well above the minimum forming temperature as it is blown back against the male form.

Care must be used in design to prevent the Plexiglas® acrylic sheet from webbing at the corners when it is blown back against the male mold. One way to overcome this tendency is to add dummy blocks to the mold to equalize stretching in all directions. Figure 26 shows a formed letter “C” made with and without dummy blocks. The heavy lines indicate corner fold produced in the formed letter made without dummy blocks. The two blocks included in cutaway portions of the other mold completely overcome this tendency.

FIGURE 25

Blowback Forming

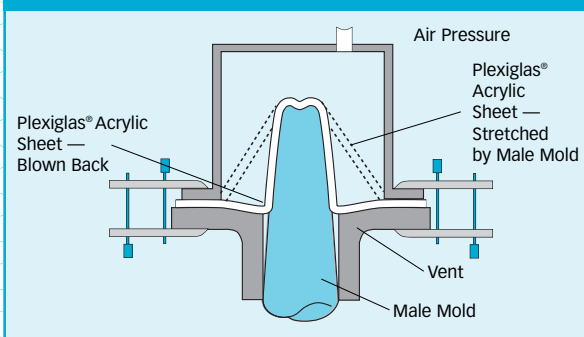
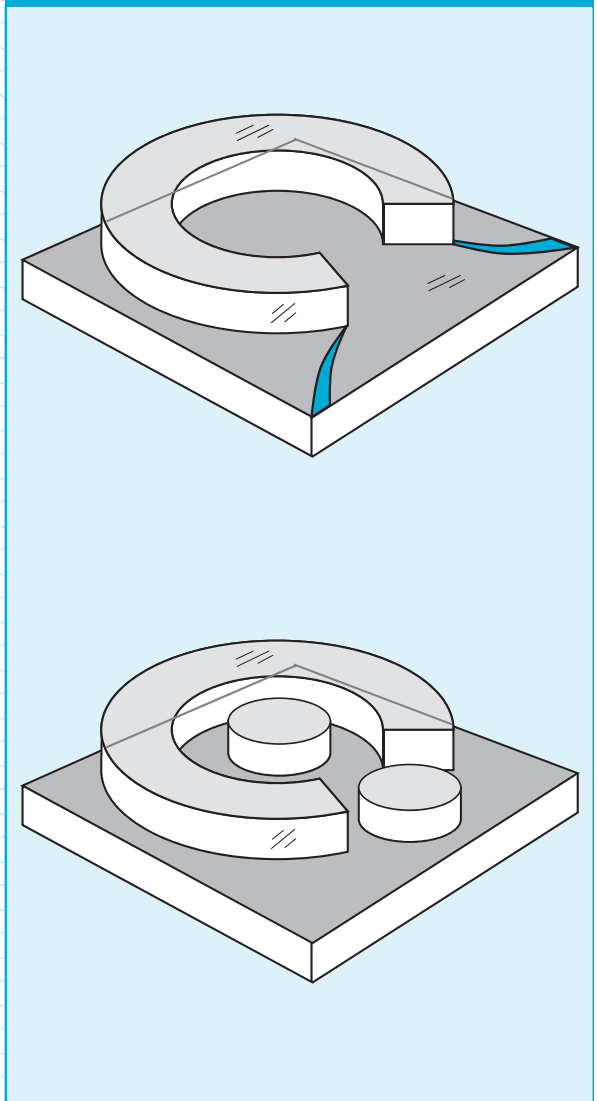

FIGURE 26

Using Dummy Block to Prevent Webbing



Billow Forming

The main advantage of billow forming (Figure 27) is good control of wall thickness.

This method consists of clamping to a pressure box a heated blank that is larger than the projected area of the part. The box must be strong and airtight. A bubble is blown in the sheet clamped to the box by admitting air to the box. The male mold is then forced down into the bubble. Contact with the mold tends to prevent further thinning due to friction and cooling. As the male mold descends the bubble will wrap around it because of the air pressure maintained in the box. The pressure should be relief-valved so that excess pressures are not built up as the male mold and formed Plexiglas® acrylic sheet displace the volume. The male mold must be vented at undercuts or any areas that trap air between the mold and the formed part. The vented air can also be used to blow the formed part off the mold.

FIGURE 27

Billow Forming

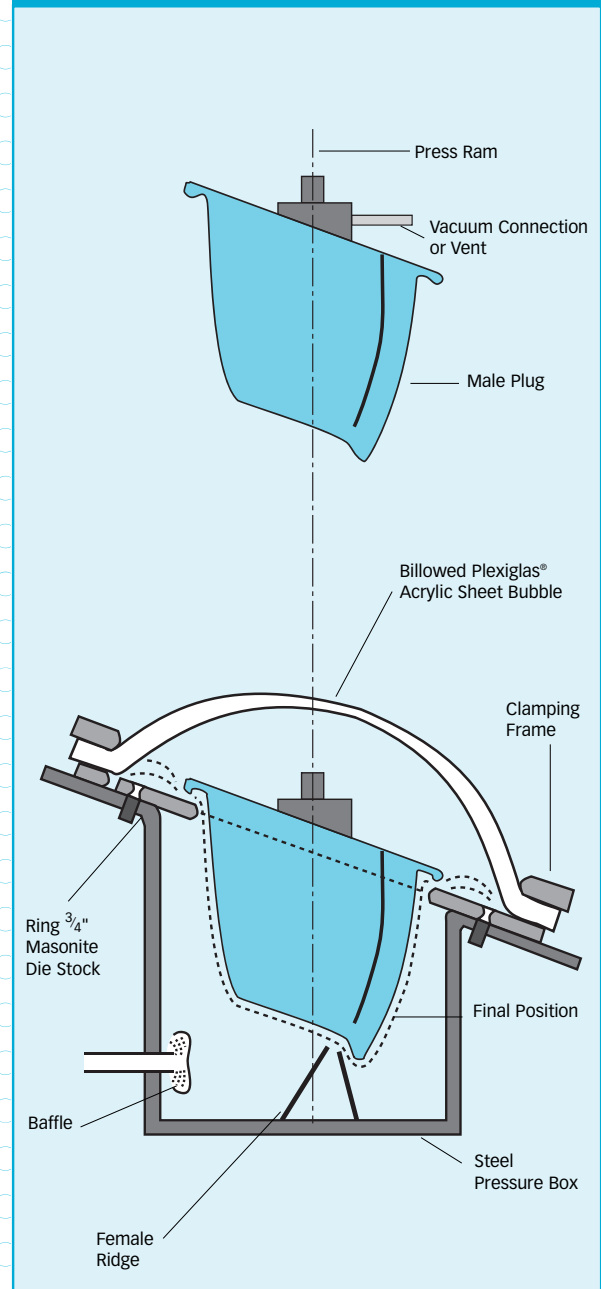

Ridge Forming

Ridge forms are open or skeletal rather than solid forms and they may be used to good advantage in many forming operations. They are generally easier and less costly to construct than solid forms.

Ridge forms may be used with nearly all methods of forming including press forming, vacuum or pressure forming, snapback or reverse blow forming and vacuum platen forming. Ridge forms contact the heated Plexiglas® acrylic sheet only along ridges necessary to determine the size and shape of the formed part. Consequently, mark-off is minimized.

Because hot Plexiglas® acrylic sheet tends to resume its original flat shape, the areas between ridges and clamping ring are stretched taut. Areas on a plane enclosed by ridges tend to form flat planes in the formed part. In other shapes with ridges that do not fall on the plane, the intervening areas tend to be concave.

One of the simplest ridge forms is that shown in Figure 28 for corrugating Plexiglas® acrylic sheet by press forming. The form consists of rows of parallel metal T-bars mounted in alternating positions on upper and lower platens.

Ridge forms combined with vacuum platens provide a simple means of forming an unlimited variety of parts with a minimum outlay for materials and equipment. Simple ridge forms are made from plywood and stock metal shapes, which are then used to vacuum form decorative Plexiglas® acrylic sheet panels.

The principles of ridge forming can be extended to the construction of both male and female forms (Figure 29) so that reverse curves, flanges and flutes can be formed with a minimum of distortion.

Several shapes can be formed in a single piece by dividing a vacuum box with partitions and using separate control valves for each compartment. The Plexiglas® acrylic sheet itself forms a seal when it is drawn against the ridges or partitions. The pressure differentials that may be used are limited by the tension in the sheet as it is stretched across the opening. A tighter seal can be made if ridges in the male form press the Plexiglas® acrylic sheet against corresponding grooves or ridges in the female form.

FIGURE 28

Ridge Forming

Corrugating Plexiglas® Acrylic Sheet (ridge forming)

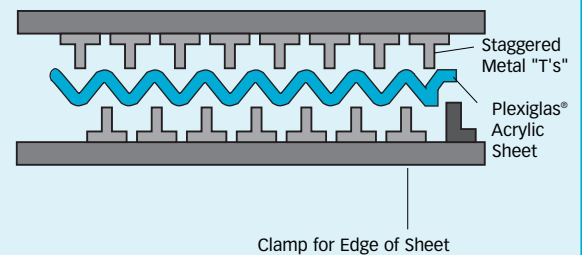
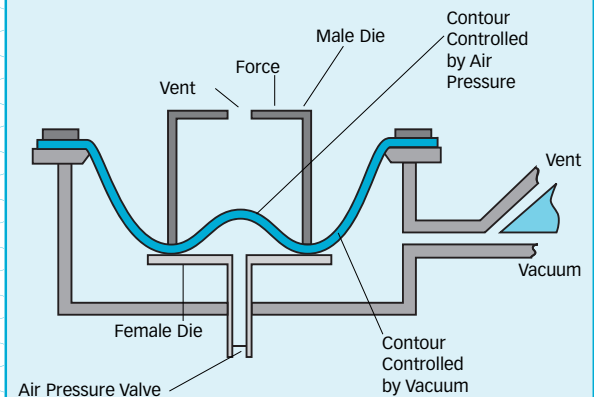

FIGURE 29

Ridge Forming Using Air Pressure and Vacuum



Male and Female Forming

Male and female forming may be used to form Plexiglas® acrylic sheet by surface molding and embossing the material between matched male and female dies. Both surfaces of the Plexiglas® acrylic sheet formed by this method are in continuous contact with the forms and will reproduce the mold surfaces if high enough pressures are used.

Matched male and female dies usually cost more than tooling used for other forming methods. These dies should be metal to withstand the high pressures that may be developed. If used hot, metal dies will prolong cooling. They should, therefore, be cored to permit heating and cooling.

Surface Embossing

Embossing is often used to produce a patterned surface finish on Plexiglas® acrylic sheet parts for applications such as lighting fixture panels where spectacular reflections might be annoying. The patterned surface is obtained by blowing the hot sheet against a mold having a textured surface finish (Figure 30).

Positive air pressures of 50 to 75 psi (4 to 6 tons total force per square foot) must be used to obtain a uniform overall pattern on cast sheet. Much lower positive pressure or vacuum pressure will produce similar results with Plexiglas® MC acrylic sheet. Large high-capacity presses are required to provide enough clamping force to resist these pressures. The press must also close quickly so that the surface of the sheet does not cool too much before forming.

Metal mold surfaces must be kept hot and temperatures must be uniform over the mold surface to prevent chilling of the sheet and loss of surface detail. If a matte finish is desired, the surface of the mold should be covered with pure white wool felt, which will act as an insulating blanket and reduce the chilling effect of the mold while producing a uniform matte surface of the Plexiglas® acrylic sheet.

FIGURE 30

Surface Embossing

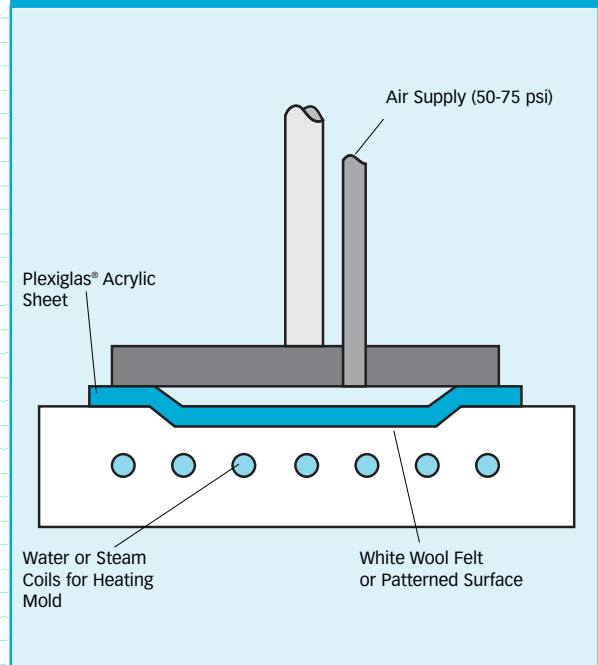

GENERAL HEALTH & SAFETY PRECAUTIONS

Care must be taken whenever thermoforming any thermoplastic including Plexiglas® acrylic sheet. The heat of thermoforming Plexiglas® acrylic sheet may result in the release of vapors or gases, including methyl methacrylate (MMA) monomer. However, thermoforming Plexiglas® acrylic sheet in accordance with recommended techniques at recommended temperatures and with adequate ventilation should not result in harmful concentrations of vapors or gases in the workplace. High concentrations of MMA vapors can cause eye and respiratory irritation, headache and nausea. The OSHA Air Contaminant Standard for MMA places the maximum permissible exposure level at a time weighted average (TWA) of 100 ppm. Altuglas International recommends a TWA for MMA of 50 ppm.

It is always good practice to provide local exhaust ventilation as close to the point of possible generation of vapors as practical. Suggestions for the design of exhaust ventilation systems are provided in *Industrial Ventilation — A Manual of Recommended Practice*, published by the American Conference of Governmental Industrial Hygienists (2004), and American National Standards Institute *Fundamentals Governing the Design and Operation of Local Exhaust Systems*, ANSI/AHAZ9.2-2001.

Before attempting to make forms or conduct grease forming with materials suggested in this manual, the user should become familiar with the properties of these materials and the precautions necessary for their safe usage. Material Safety Data Sheets should be available from the manufacturer for these purposes.

Plexiglas® acrylic sheet is a combustible thermoplastic material. The same fire precautions observed with the handling and use of any ordinary combustible material should be observed when handling, storing, or using Plexiglas® acrylic sheet.

Altuglas International Sales Offices

For more information, call your local Altuglas International sales office or Altuglas International headquarters.

Americas Headquarters

Altuglas International
Arkema Inc.
2000 Market Street
Philadelphia, PA 19103-3222
USA
Tel.: 800-523-1532
215-419-7000
Fax: 215-419-5511

Detroit Office

Altuglas International
Arkema Inc.
1050 S. Milford Road
Suite 102
Highland, MI 48357
USA
Tel.: 248-887-2245
Fax: 248-887-0452

Chicago Office

Altuglas International
Arkema Inc.
2300 N. Barrington Road
Suite 432
Hoffman Estates, IL 60195
USA
Tel.: 847-490-8455
Fax: 847-884-0353

Mexico Office

Arkema SA de CV
Río San Javier 10
Viveros del Río, Tlalnepantla
54060 Edo. de Mexico
Mexico
Tel.: 52-555-366-4166
Fax: 52-555-362-0699

Brasil Office

Arkema Quimica Ltda.
Av. Ibirapuera
2033 Sao Paulo – SP 04029-901
Brasil
Tel.: 55-11-5056-8579
Fax: 55-11-5051-4780

The statements, technical information and recommendations contained herein are believed to be accurate as of the date hereof. Since the conditions and methods of use of the product and of the information referred to herein are beyond our control, Arkema expressly disclaims any and all liability as to any results obtained or arising from any use of the product or reliance on such information; NO WARRANTY OF FITNESS FOR ANY PARTICULAR PURPOSE, WARRANTY OF MERCHANTABILITY OR ANY OTHER WARRANTY, EXPRESS OR IMPLIED, IS MADE CONCERNING THE GOODS DESCRIBED OR THE INFORMATION PROVIDED HEREIN. The information provided herein relates only to the specific product designated and may not be applicable when such product is used in combination with other materials or in any process. The user should thoroughly test any application before commercialization. Nothing contained herein constitutes a license to practice under any patent and it should not be construed as an inducement to infringe any patent and the user is advised to take appropriate steps to be sure that any proposed use of the product will not result in patent infringement.

See MSDS for Health & Safety Considerations.

Altuglas® and Plexiglas® are registered trademarks of Arkema.
All other trademarks listed are the property of their owners.
©2006 Arkema Inc. All rights reserved.